

A guide to select the correct bell-housing and drive coupling components

DATA REQUIRED

Electric motor power/motor size
 Manufacturer and pump type

TO VERIFY:

- 1 - Pump and motor shaft dimensions (see page 69)
- 2 - Shaft and flange pump (see pump data sheet)

Example:

- Electric motor 2 kW - 4 poles - Motor size 110/112
- Atos pump code PFE31 - Shaft 1

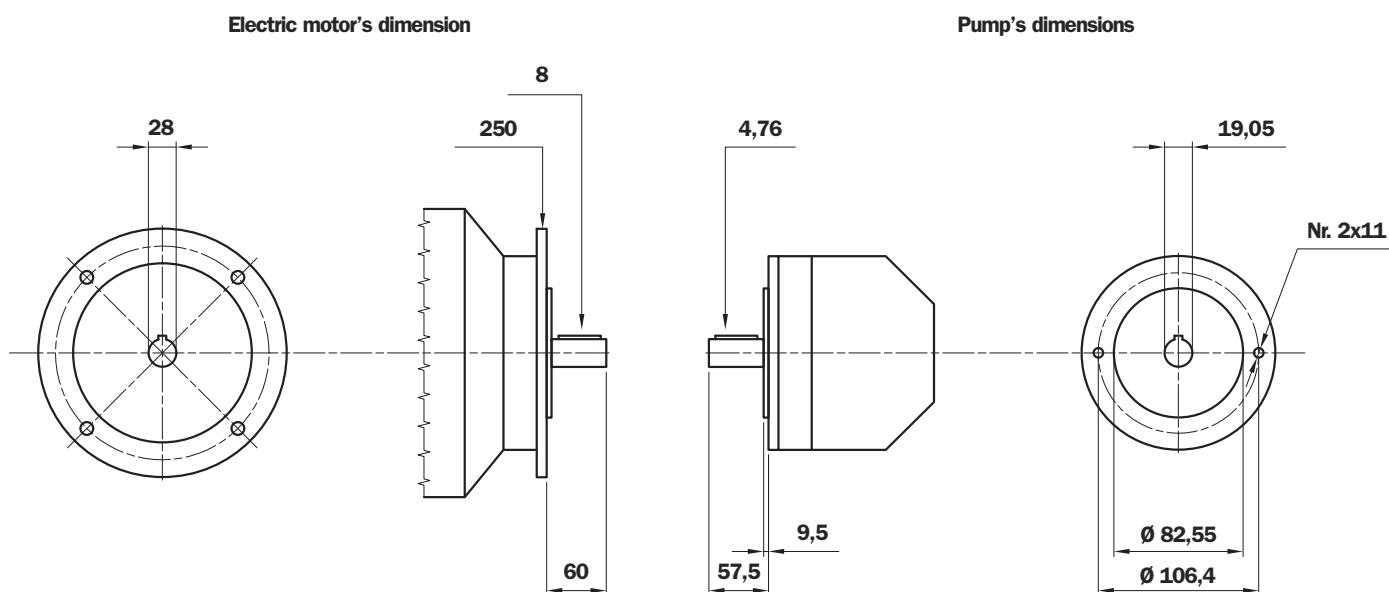

Bell-Housing's length calculation

- $H = 60 + 18 + 57,5 = 135,5$ mm (18= Sp spider - see page 49)
- Choose type of bell-housing (LMC - LMS)
 - For LMC see tab. 3 at page 11
 - For LMS see tab. 21 at page 32
 - For MODUL 2/3 see at page 36

Note: The length of bell-housing must be \geq than the length calculated (135,5 mm)

Case A - solution with LMC bell-housing

Tab. 3 at page 11 - for electric motor 2kW LMC 250
 LMC 250 bell-housing with height $\geq 135,5$ - LMC250AFSQ

- The bell-housing code must be completed with drilling pump code (see tab. 34 at page 47)
 For the specific case C= 82,5 - Nr. 2 holes M10: Code drilling O60
- Definitive bell-housing code **LMC250AFSQ060**

Case B - solution with LMS bell-housing

Tab. 21 at page 32 - for electric motor 2kW LMS 250
 LMS 250 bell-housing with height $\geq 135,5$ - LMS250AFSQ

- The bell-housing code must be completed with drilling pump code (see tab. 34 at page 47)
 For the specific case C= 82,5 - Nr. 2 holes M10: Code for. 060
- Definitive bell-housing code **LMS250AFSQ060**

Choose coupling

- **Motor half-coupling** (see tab. 37 at page 50)

- For electric motor GR 100/112, the half-coupling is **SGEA21M05060**

- **Spider** (see tab. 35 - 36 at page 49)

- For SGEA21, EGE2 - EGE2RR

- (choose spider material on the base of the application, oil, temperature and cycle machine, etc.)

- **Pump half-coupling**

- Choose the drilling code tab. 43 - 44 at page 53 for shaft 19,05 - Ch. 4,76 - code: **G01**

- Half-coupling length = L BH length - THK Spider - THK Spigot

- LMC= 138 mm - 60 - 18 - 9,5= 50,5 mm

- LMS= 148 mm - 60 - 18 - 9,5= 60,5 mm

- LMC - Choose the half-coupling's length on tab. 38 at page 50 $\leq 50,5$ mm.

- LMS - Choose the half-coupling's length on tab. 38 at page 50 $\leq 60,5$ mm.

- LMC - Availabe length for SGEA21= 50 mm

- LMS - Availabe length for SGEA21= 60 mm

- LMC=LMS - Code half-coupling code: **SGEA21G01050**

**Software for automatic calculation available on the web site
www.mpfiltri.com - tools - software**

Vanu / Pumps / Screw pumps

AKA
AxNW132006

Pump
Manufacturer: ATOS
Pump type: PFE
Pump model: PFE31 Shaft 1

HYDRAULIC PUMP - Technical Data
L1: 37.5
dl: 19.05
Ch1: 4.76
e: 9.5
Pd: 82.55
De: 106
Rc: 2
F: M0

Electric Motor
N. Poles: 2P
Type: M3-B5
Size: 100-112
Sec: 3-4
Isp: 4-5,44

ELECTRIC MOTOR - Technical Data
L1: 60
dl: 28
Fig.: 250
Ch1: 8

Coupling material
 Aluminum
 Cast iron
 Other alternative material

Result
Coupling: M01 - 21066
Drilling Pump: 5000
Pump Shaft: G01
Motor Shaft: M0

CLICK HERE TO PROCEED

Result
Monobloc Bellhousing:
Modular Bellhousing:
Silenced Bellhousing:
Monobloc Bellhousing: Pump half-coupling with grub screw
For other solution please contact technical department
Modular Bellhousing: OK
Silenced Bellhousing: OK

Note: For multi pumps we recommend to use a specific support on the base of the pump's dimensions and weight.

Half-coupling SGE*** series

The half-couplings series SGE*** allow secure transmission between the electric motor and the driven side; they are able to absorb shocks and vibration, in addition to compensating radial misalignment, angular and axial.

The assembly of the couplings can be horizontal/vertical, withstanding vibration and load reversals.

The complete range of couplings are extrapolated from the on-line software, with a length equal than the shaft on which must be mounted and they are completed with grub screw for fixing located on the key.

Available for cylindrical shaft with metric and imperial dimensions as well for splined shafts as per specification DIN, ISO and SAE.

Admissible misalignment radial, angular and axial

Max admissible radial misalignment

| Half coupling | R (mm) |
|---------------|--------|
| SGE * 01 | 0,5 |
| SGE * 21 | 1,0 |
| SGE * 31 | 1,0 |
| SGE * 40 | 1,0 |
| SGE * 51 | 1,5 |
| SGE * 60 | 1,5 |
| SGE * 80 | 2,0 |
| SGE * 90 | 2,0 |

Max admissible angular misalignment

| Half coupling | β (°) |
|---------------|-------------|
| SGE * 01 | |
| SGE * 21 | |
| SGE * 31 | |
| SGE * 40 | 1,5° |
| SGE * 51 | |
| SGE * 60 | |
| SGE * 80 | |
| SGE * 90 | |

Max admissible angular misalignment

| Half coupling | A (mm) |
|---------------|--------|
| SGE * 01 | 2,0 |
| SGE * 21 | 2,5 |
| SGE * 31 | 3,0 |
| SGE * 40 | 3,5 |
| SGE * 51 | 3,5 |
| SGE * 60 | 3,5 |
| SGE * 80 | 4,0 |
| SGE * 90 | 5,0 |

Normative ATEX 94/9/CE

Half-couplings SGE*** series are available to use in hazardous area.

The couplings are certified according to ATEX 94/9/CE (ATEX 95).

Category certified 2G - area 1 and 2.

Other information available on our web site "www.mpfiltri.com".

MP Filtri couplings are developed with:

CAD 3D



FEM (calculation)



Drawings 3D available on website www.mpfiltri.com at section TOOLS/2D-3D COMPONENTS

The half-couplings SGE*** series are in conformity to normative **DIN 740/2**.
The max torque to transmit is always less than the max torque that the coupling can transmit.

Examples verification of the coupling

Torque transmitted by electric motor:

Mt: $9560 \times \text{kW} / \text{rpm} = \text{Nm}$

Me > $\text{Mt} \times \text{S} = \text{Nm}$

Where:

Mt: Torque transmitted by electric motor

Me: Torque transmitted by coupling (see table 14)

kW: Power of electric motor

Rpm: Revolutions per minute of electric motor

S: Service factor (see table 14)

TABLE 1

| | |
|--|------------|
| Small pumps, uniform load, low operating pressures e.g. rotary action machine tools - 5/8 work cycles per hour | 1.3 |
| Small pumps, uniform load, high working pressures e.g. lifting equipment - 120-150 work cycles per hour | 1.5 |
| Pumps, non-uniform load e.g. lifting equipment - 280-300 work cycles per hour | 1.7 |

Example

Electric motor, 4 pole - 4 kW

hydraulic pump, uniform load, low operating pressure

Mt: $9560 \times 4 / 1500 = 25.45 \text{ Nm}$

Me > $25.49 \times 1.3 = 33 \text{ Nm}$

Half-coupling SGEA21 meets the above requirement.

Select the half-coupling of the calculated size from the motor half-couplings table.

Note: When selecting the coupling, remember that for pumps with splined shaft, only cast iron couplings of the SGEG series can be used.

Determine the size of the coupling according to the type of installation and application envisaged, on the basis of the following formulas and tables:

TABLE 2

| Half-coupling type | External diameter mm | Nominal torque Me - Nm | Maximum transmissible torque Me - Nm |
|--------------------|-------------------------|---------------------------|---|
| ALUMINIUM | SGEA01 | 15 | 20 |
| | SGEA21 | 160 | 190 |
| | SGEA31 | 340 | 380 |
| | SGEA51 | 550 | 620 |
| CAST IRON | SGEG01 | 20 | 30 |
| | SGEG30 | 400 | 450 |
| | SGEG40 | 550 | 620 |
| | SGEG60 | 760 | 850 |
| | SGEG80 | 2200 | 2500 |
| | SGEG90 | 5500 | 6100 |
| STEEL | SGES40 | 550 | 620 |
| | SGES60 | 760 | 850 |
| | SGES80 | 2200 | 2500 |

Nominal and maximum torque values are referred to couplings assembled with standard flexible spiders of the **EGE**** series (see page 49).

Where higher torques are to be transmitted, use flexible spiders of the **EGE**RR** series (see page 49).

Noise

Noise is a particularly pervasive problem so much so that there have been statutory regulations in place now for some years, designed to limit harmful occupational exposure. Many of the machines used in industry today are equipped with oil-hydraulic systems, which happen to be a major source of noise.

1. Theory and definition of noise

From a health and hygiene standpoint, noise can be defined as an unpleasant and undesirable sound, or an unpleasant and annoying or intolerable auditory sensation (noise being any sound phenomena that may be accompanied by sensations of disturbance and pain). By definition, acoustic phenomena are oscillatory in character, propagated in a flexible medium and causing pressure variations at the points, and the areas adjacent to those points, through which they pass.

2. Sound

Technically considered, certain elements must be present simultaneously for acoustic phenomena to occur:

- Sound source
- Transmission medium
- Receiver

Motor and pump unit

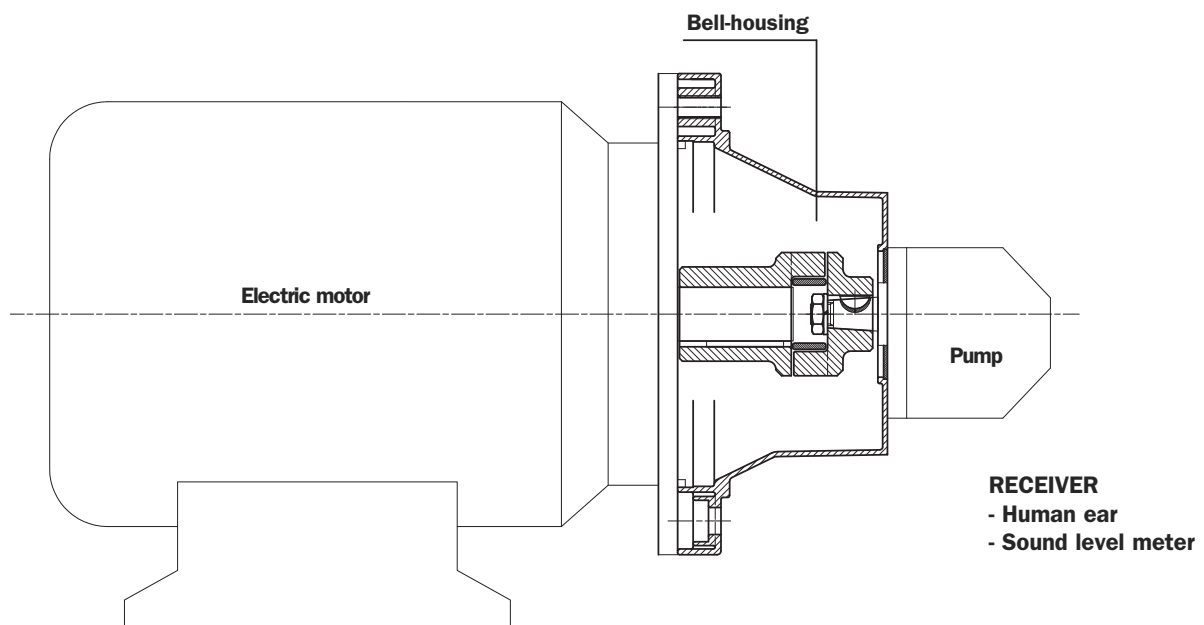

The **electric motor** and the **pump**, together with the drive coupling, are the **SOURCE OF THE NOISE**.

The **Bell-housing** is the noise transmission medium.

Depending on whether the monobloc bell-housing is a rigid or low noise type, there will be variations in the flexible properties of the transmission medium.

The acoustic phenomena are dissimilar in the two cases, given the differences in pressure variation and particle displacement.

Assembly of motor and pump unit

As mentioned in the presentation, low noise bell-housing will help to attenuate the transmission of vibrations and the emission of noise generated by the system.

Self-evidently, however, the mere adoption of a low noise bell-housing will achieve little unless the motor and pump are correctly installed on the machine, or on the tank of the hydraulic power unit.

- Should be followed in order to achieve best possible results and correct installation:

1. Motor and pump unit mounted horizontally on oil tank lid

- The suction pipe attached to the pump must be rigid, and fitted using a resilient bulkhead flange of the FTA series, which helps to cushion the vibrations propagated between the pipe and the tank lid. If pipes need to be bent, the radius of curvature must be at least 3 times the pipe diameter. Do not use elbow fittings, as these will significantly increase pressure losses.
- The pressure pipeline of the pump must be flexible, and long enough to include bends with the minimum radius of curvature recommended by the manufacturer for the specified operating pressure.
- The return pipeline running from the service to the filter must be flexible. Where oil is returned directly to the tank of the hydraulic power unit through a rigid pipe, it is advisable to use a resilient bulkhead flange of the FTR series, which helps to cushion the vibrations propagated between the pipe and the tank lid.
- Anti-vibration devices (resilient mounts or damping rods) must be located under the feet of the electric motor or the PDM foot brackets, depending on the mounting position of the motor.
- The lids of hydraulic oil tanks must be sturdy enough to support the load they carry.

2. Motor and pump unit mounted horizontally on machine

- As a matter of good practice, the oil tank and motor-pump unit should be mounted on a single supporting frame of strength sufficient to support the load.
- If the hydraulic system is fitted with a side-mounted filter, the suction pipeline to the pump must be flexible, and long enough to include bends with the minimum radius of curvature recommended by the manufacturer.
- If the suction filter is not side mounted, the pipeline should be rigid and installed in conjunction with a compensating coupling.
- The pressure pipeline of the pump must be flexible, and long enough to include bends with the minimum radius of curvature recommended by the manufacturer for the specified operating pressure.
- The return pipeline running from the service to the filter must be flexible. Where oil is returned directly to the tank of the hydraulic power unit through a rigid pipe, it is advisable to use a resilient bulkhead flange of the FTR series, which helps to cushion the vibrations propagated between the pipe and the tank lid.
- Anti-vibration devices (resilient mounts or damping rods) must be located under the feet of the electric motor or the PDM foot brackets, depending on the mounting position of the motor.

Note: The above guidelines are indicative only, and subordinate to the solutions adopted ultimately by design engineers.

In conclusion: For best results, in any event, the motor-and-pump unit should be incorporated into the hydraulic system in such a way that no one component is rigidly associated with another, resulting in the propagation of vibration, and consequently noise.

Table of summary MODUL 2/3

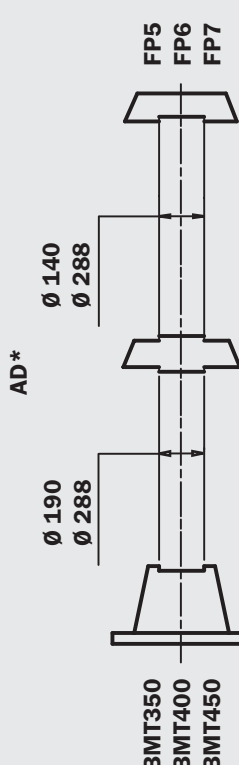
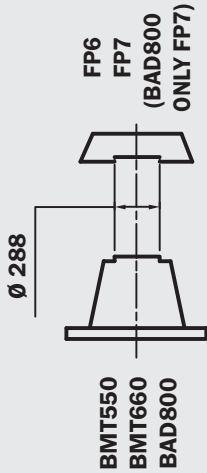
| | 5.5 - 7.5 kW | 11 - 22 | 30 | 37 - 45 | 55 - 90 | 110 - 200 | 250 - 400 |
|----------------|---|-------------------------------------|-------------------------------------|--------------------------------------|--------------------------------------|---------------------------------------|---------------------------------------|
| | 7.5 - 10.2 Hp Size 225 - D.450 | 15 - 30 Hp Size 160/180 D.350 | 40.80 Hp Size 200 - D.350 | 50.32 - 61.2 Hp Size 225 - D.450 | 75 - 125 Hp Size 250/280 D.550 | 150 - 272 Hp Size 315 - D.660 | 340 - 544 Hp Size 355/400 D.800 |
| MODUL 3 |  <p>AR*</p> <p>BMT300 BMT350</p> <p>Ø 190</p> <p>Ø 85</p> <p>FR1*</p> <p>Kit of assembly KVG5 (Q.ty 1) + Kit of assembly KVG1 (Q.ty 1)</p> | | | | | | |
| |  <p>AD*</p> <p>Ø 190</p> <p>Ø 288</p> <p>Ø 140</p> <p>Ø 288</p> <p>BMT350 BMT400 BMT450</p> <p>FP5 FP6 FP7</p> <p>Kit of assembly KVG5/7 (Q.ty 2)</p> | | | | | | |
| MODUL 2 |  <p>Ø 288</p> <p>BMT550 BMT660 BAD800</p> <p>FP6 FP7 (BAD800 ONLY FP7)</p> <p>Kit of assembly KVG6/7 (Q.ty 1)</p> | | | | | | |
| | 5.5 - 7.5 kW | 11 - 22 | 30 | 37 - 45 | 55 - 90 | 110 - 200 | 250 - 400 |
| 7.5 - 10.2 Hp | 15 - 30 Hp Size 160/180 D.350 | 40.80 Hp Size 200 - D.350 | 50.32 - 61.2 Hp Size 225 - D.450 | 75 - 125 Hp Size 250/280 D.550 | 150 - 272 Hp Size 315 - D.660 | 340 - 544 Hp Size 355/400 D.800 | |

Monobloc bell-housings

LMC series

LMC series monobloc bell-housings are used as connecting elements between **B3 - B5** flanged **UNEL-MEC** electric motors and a wide range of hydraulic pumps available on the international market.

With special machining, they can be modified to serve as motors base that will accept standard flanges manufactured by **MP Filtri S.P.A.** (MODUL-2).

Thanks to their considerable versatility and to the extensive range of pump flanges available, **LMC** series monobloc bell-housings are compatible with electric motors from **size 80, rated 0.5 kW**, up to **size 225, rated 37/45 kW**, and therefore suitable for most applications.

Technical specifications

LMC

Materials

- **Monobloc bell-housing**
Pressure diecast aluminium alloy.
- **Pump flange**
Pressure diecast aluminium alloy.
- **Foot bracket**
Pressure diecast aluminium alloy.

Temperature

- $-30^{\circ}\text{C} \div +80^{\circ}\text{C}$
For temperatures outside this range, consult the MP Filtri Technical and Sales Department.

Compatibility with fluids

- **Monobloc bell-housings compatible for use with:**

Mineral oils

Types HH-HL-HM-HR-HV-HG, to ISO 6743/4 standard

Water based emulsions

Types HFAE - HFAS, to ISO 6743/4 standard

Water glycol

Type HFC, to ISO 6743/4 standard

Ask for anodized version



Special Applications

- **Any applications not covered by the normal indications contained in this catalogue must be evaluated and approved by the MP Filtri Technical and Sales Department**

Monobloc bell-housing

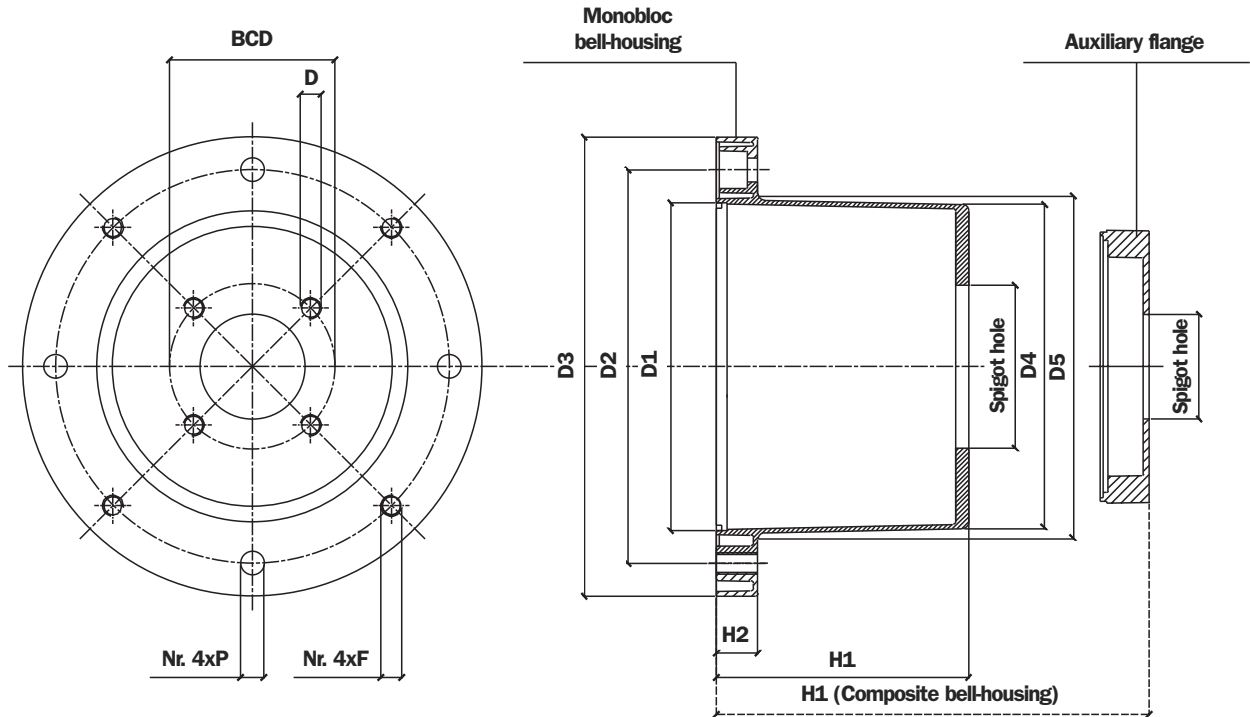

The auxiliary flange, if specified, is supplied already fitted to the bell-housing (MODUL-2).

- For loose components see pages 15 - 16 - 17
- Check that the pump interface dimensions are compatible with those of the bell-housing

Note: The hole made in the tank cover should be 2 mm larger than dimension D5

Machining tolerances

| | |
|-------------|-----------|
| D1 | F8 |
| Spigot hole | H7 |
| H1 | ± 0,15 mm |

Concentricity of D1/Spigot hole

| | |
|-------------------|---------|
| LMC 200 - LMC 350 | 0,20 mm |
| LMC 300 - LMC 450 | 0,25 mm |

TABLE 3

| Electric motor, 4-pole, 1500 rpm | | | | Dimensions of LMC monobloc bell-housing | | | | | | | | | | | |
|----------------------------------|-----------|----------|--------|---|---------------------------|-----|-----|-----|-----|-----|----------------|----|-----|----|---------------------|
| Frame size | kW | Hp | Shaft | Bell-housing code | Foot bracket code | D1 | D2 | D3 | D4 | D5 | H1 | H2 | F | P | Spigot hole Minimum |
| 80 | 0.53-0.75 | 0.75-1 | 19x40 | LMC 200 | PDM A 200 | 130 | 165 | 200 | 125 | 135 | | 18 | M10 | 11 | 50 |
| 90 | 1.1-1.5 | 1.5-2 | 24x50 | LMC 200 | PDM A 200 | 130 | 165 | 200 | 125 | 135 | | 18 | M10 | 11 | 50 |
| 100-112 | 2.2-4 | 3-5.5 | 28x60 | LMC 250 | PDM A 250 | 180 | 215 | 250 | 175 | 186 | | 19 | M12 | 14 | 50 |
| 132 | 5.5-7.5 | 7.5-12.5 | 38x80 | LMC 300 | PDM A 300 | 230 | 265 | 300 | 230 | 235 | | 23 | M12 | 14 | 80 |
| 160 | 11-15 | 15-20 | 42x110 | LMC 350 | PDM A 350 | 250 | 300 | 350 | 240 | 254 | | 31 | M16 | 18 | 50/80* |
| 180 | 18.5-22 | 25-30 | 48x110 | LMC 350 | PDM A 350 | 250 | 300 | 350 | 240 | 254 | | 31 | M16 | 18 | 50/80* |
| 200 | 37 | 45 | 55x140 | LMC 400 | / | 300 | 350 | 400 | 280 | 305 | | 31 | M16 | - | 80 |
| 225 | 37-45 | 50-60 | 60x140 | LMC 450 | / | 350 | 400 | 450 | 320 | 350 | | 31 | M16 | - | 80 |
| | | | | | For dimension see page 55 | | | | | | See Tab. 4 - 5 | | | | |

To determine dimension H1 of the bell-housing see table 12
 For dimensions of the foot bracket see page 55

* The minimum spigot hole \varnothing 50 is related to the LMC350AFSY (see table 4)
 The minimum spigot hole \varnothing 80 is related to the LMC350AFSU (see table 4)

LMC bell-housing, dimension H1

TABLE 4

| Monobloc bell-housing | | |
|-----------------------|-----|-------------|
| Code | H1 | Weight (kg) |
| LMC200AFSJ*** | 100 | 0,75 |
| LMC200AFSW*** | 125 | 0,95 |
| LMC250AFSM*** | 114 | 1,50 |
| LMC250AFSQ*** | 138 | 1,60 |
| LMC250AFSR*** | 159 | 1,75 |
| LMC300AFST*** | 155 | 3,20 |
| LMC300AFSX*** | 170 | 3,30 |
| LMC350AFSY*** | 178 | 4,80 |
| LMC350AFSU*** | 194 | 4,90 |
| LMC400AFSV*** | 201 | 6,50 |
| LMC450AFSZ*** | 250 | 9,00 |

TABLE 5a

| Modul 2 bell-housing | | |
|----------------------|-----|-------------|
| Code | H1 | Weight (kg) |
| LMC200AFRB*** | 125 | 1,85 |
| LMC200AFRC*** | 133 | 1,95 |
| LMC200AFRD*** | 158 | 2,10 |
| LMC250AFRB*** | 156 | 2,50 |
| LMC250AFRC*** | 161 | 2,75 |
| LMC250AFRA*** | 185 | 4,20 |
| LMC300AFRB*** | 191 | 4,45 |
| LMC300AFRC*** | 193 | 4,60 |
| LMC300AFRD*** | 201 | 4,95 |
| LMC300AF5A*** | 192 | 4,50 |
| LMC300AF5B*** | 198 | 4,80 |

TABLE 5b

| Modul 2 bell-housing | | |
|----------------------|-----|-------------|
| Code | H1 | Weight (kg) |
| LMC350AF5A*** | 218 | 5,90 |
| LMC350AF5B*** | 224 | 6,15 |
| LMC350AF6A*** | 239 | 6,80 |
| LMC350AF6B*** | 252 | 7,30 |
| LMC400AF5A*** | 228 | 7,50 |
| LMC400AF5B*** | 234 | 7,90 |
| LMC400AF6A*** | 247 | 8,50 |
| LMC400AF6B*** | 260 | 9,00 |
| LMC450AF5A*** | 226 | 10,00 |
| LMC450AF5B*** | 234 | 10,40 |
| LMC450AF6A*** | 295 | 11,20 |
| LMC450AF6B*** | 308 | 11,60 |

Note: The three asterisks in the designation code represent the three digits identifying the pump interface (see page 47).

Specified tightening torques for auxiliary flange

- FR* 18 Nm
- F5* 100 Nm
- F6* 180 Nm

Recommended tightening torques for motor/pump assembly bolts

- M6 10 Nm
- M8 24 Nm
- M10 50 Nm
- M12 84 Nm
- M14 135 Nm
- M16 205 Nm
- M18 280 Nm
- M20 400 Nm
- M22 530 Nm
- M24 690 Nm

These values are calculated to exploit the performance of the bolt at 70% of its elastic limit.

This means in practice that the shank of the bolt will be stressed typically to 60-70% of its limit of elasticity in the course of being tightened.

The values indicated are valid for hexagon head bolts to UNI 5737 and hexagon socket screws to UNI 5931, property class 8.8, tightened by degrees using a torque wrench.

If bolts or screws are tightened using impact or hammer action drivers, the applied torque should be reduced by 10%.

Comparative table

| MP Filtri | | OMT | Hydrapp | Raja | KTR |
|------------|---------------|----------|---------|------------------|-------------|
| New code | Old code | code | code | code | code |
| LMC200A*** | LMB200A100*** | TH20A*** | / | R200/99-115/... | PK200/3/... |
| LMC200A*** | / | TH1*** | HLC1 | R200/120-135/... | PL200/8/... |
| LMC250A*** | LMB250A109*** | TH2*** | HLC3 | R250/120-135/... | PL250/6/... |
| LMC300A*** | LMB300A130*** | TH3*** | HLC5 | R300/155-170/... | PL300/4/... |
| LMC350A*** | LMB350A179*** | TH4*** | HLC8 | R350/173-194/... | PK350/4/... |
| LMC400A*** | / | TH15*** | HLC12 | R400/194-210/... | PK400/4/... |
| LMC450A*** | / | TH18*** | / | R450/250-210/... | PK450/4/... |

