

REMOTE CONTROL RANGE 2016



TECHNICAL CATALOGUE



1st edition HRC.02

*This catalogue shows the product in the most standard configurations.
Please contact our Sales Dpt. for more detailed information or special requests.*

WARNING!

*All specifications of this catalogue refer to the standard product at this date.
Walvoil, oriented to a continuous improvement, reserves the right to
discontinue, modify or revise the specifications, without notice.*

**WALVOIL IS NOT RESPONSIBLE FOR ANY DAMAGE CAUSED BY AN
INCORRECT USE OF THE PRODUCT.**

GENERAL INDEX

HYDRAULIC REMOTE CONTROL



10

RCX

16

RCY

18

RCL

20

RCL3

22

RCM

28

RCB

FOOT PEDAL



34

RCP

38

RCF

42

RCD

46

RCS

52

RCT

58

RCV

SUPPLY UNIT



62

SU - SE

METERING CURVE CLASSIFICATION 70

RETURN SPRING CLASSIFICATION 79





HANDLES CLASSIFICATION 80



HYDRAULIC REMOTE CONTROL

Hydraulic remote controls that Hydrocontrol work by means of direct pressure reducing valve. They are especially suitable for remote-controlling distributors, pumps and motors, in small space thus ensuring high performances, quick and reliable responses both on mobile machinery and on industrial equipment. Hydrocontrol range includes different hydraulic remote controls that are manufactured using proper material whose processing is carried out with technology methods, the most sophisticated tests and inspections, thus assuring a product at high reliability, suitable for strictest and exacting works.

QUICK REFERENCE GUIDE

Type	Description	Number of ports	Inlet pressure (bar)	Oil input capacity (l/min)	Weight (kg)	Standard threads
RCX	 2 axis single lever remote control	4	100	12	2,5	G 1/4 9/16"18 UNF
RCY	 2 axis single lever remote control reduced operating force	4	100	12	2,5	G 1/4 9/16"18 UNF
RCL	 2 axis single lever remote control with electromagnetic detent	4	40	12	2,9	G 1/4 9/16"18 UNF
RCL3	 2 axis lever + single axis lever remote control with electromagnetic detent	4 + 2	40	12	4,8	G 1/4 9/16"18 UNF
RCM	 Stackable single axis levers remote control	2	60	12	1,5	G 1/4 9/16"18 UNF
RCB	 Single axis levers two modules remote control	4	60	12	3,2	G 1/4 9/16"18 UNF



GENERAL SPECIFICATION

Description	Value
Maximum input pressure	100 bar - 1450 PSI
Maximum back pressure on tank line	3 bar - 43,5 PSI
Maximum flow on ports	12 l/min - 3 GPM
Hysteresis	< 1 bar - < 14,5 PSI
Hydraulic fluid	Mineral oil HL, HM (o HLP DIN 51524)
Fluid temperature range	-20°C / +80°C
Fluid viscosity range	10 ÷ 300 cSt
Max contamination level	9 (NAS 1638) - 20/18/15 (ISO 4406:1999)
Recommended filtration	β10 > 75 (ISO 16889:2008)
Leakage (singol port)	3 cc/min (with 50 bar of pressure)
Body material	Cast iron
Surface coating	Zin plated (international standards 2000/53/CE RoHS)
Plunger material	Stainless steel
Plunger guide material	Brass

OPERATING PRINCIPLE

Hydraulic remote controls and foot pedals works according to the principle of direct-acting pressure reducing valves. In rest position, the Joystick lever or kit pedal is held in neutral by return spring; inlet port P is closed and ports are connected to tank port T. By selecting control lever, plunger compresses return spring and reaction spring through cam mechanism; consequently it shifts spool and opens connection holes between inlet port P and service ports. This causes a pressure increase on service ports that is proportional to the control lever stroke and the reaction spring.

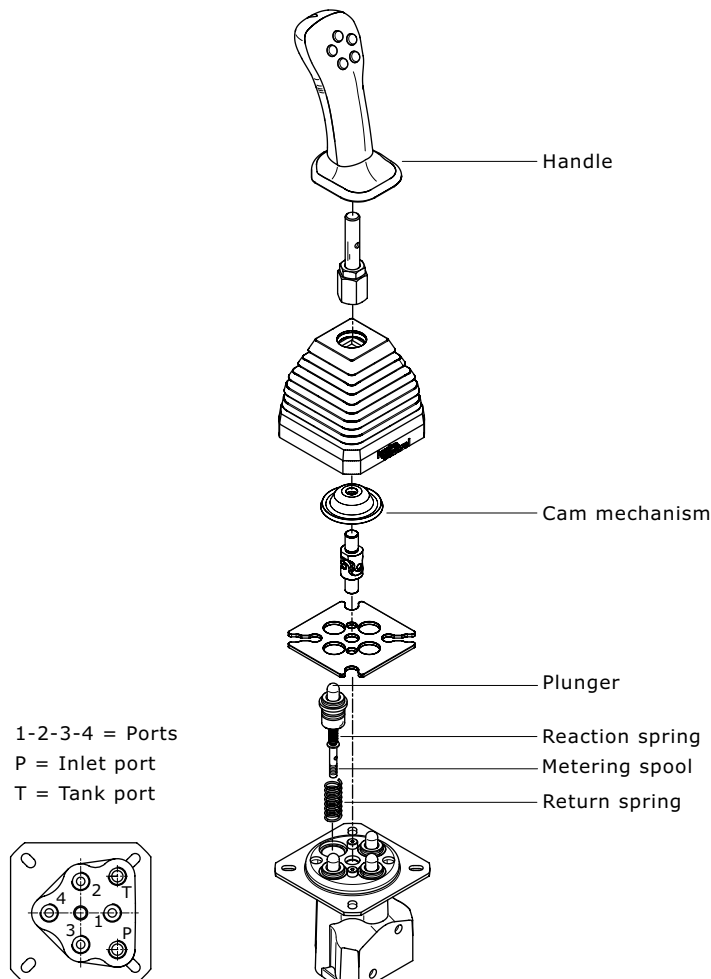









FOOT PEDAL

The wide range of foot controls, available in a variety of configurations, allows the best choice of product to be made in both functional and dimensional terms. The different models offer several solutions when it comes to hydraulic connection layout – always guaranteeing simple, straightforward installation. The new RCS and RCT series also include different foot control types, with special care applied to their ergonomic and design features.

QUICK REFERENCE GUIDE

Type	Description	Number of ports	Inlet pressure (bar)	Oil input capacity (l/min)	Weight (kg)	Standard threads
RCP	 Foot pedal 2 service ports with side ports and reduced body height	2	100	12	3,4	G 1/4 9/16"18 UNF
RCF	 Foot pedal lower ports	2	100	12	4,1	G 1/4 9/16"18 UNF
RCD	 Double foot pedal lower ports	2	60	12	3,2	G 1/4 9/16"18 UNF
RCS	 Foot pedal lower ports	2	100	12	4,1	G 1/4 9/16"18 UNF
RCT	 Double foot pedal lower ports	4	100	12	5,1	G 1/4 9/16"18 UNF
RCV	 Hydraulic remote control one service port	1	100	12	1	G 1/4 9/16"18 UNF



GENERAL SPECIFICATION

Description	Value
Maximum input pressure	100 bar - 1450 PSI
Maximum back pressure on tank line	3 bar - 43,5 PSI
Maximum flow on ports	12 l/min - 3 GPM
Hysteresis	< 1 bar - < 14,5 PSI
Hydraulic fluid	Mineral oil HL, HM (o HLP DIN 51524)
Fluid temperature range	-20°C / +80°C
Fluid viscosity range	10 ÷ 300 cSt
Max contamination level	9 (NAS 1638) - 20/18/15 (ISO 4406:1999)
Recommended filtration	β10 > 75 (ISO 16889:2008)
Leakage (singol port)	3 cc/min (with 50 bar of pressure)
Body material	Cast iron
Surface coating	Zin plated (international standards 2000/53/CE RoHS)
Plunger material	Stainless steel
Plunger guide material	Brass

OPERATING PRINCIPLE







Hydraulic remote controls and foot pedals works according to the principle of direct-acting pressure reducing valves. In rest position, the Joystick lever or kit pedal is held in neutral by return spring; inlet port P is closed and ports are connected to tank port T. By selecting control lever, plunger compresses return spring and reaction spring through cam mechanism; consequently it shifts spool and opens connection holes between inlet port P and service ports. This causes a pressure increase on service ports that is proportional to the control lever stroke and the reaction spring.



SUPPLY UNIT

Supply unit range is used when oil is needed at a pressure that is lower than the pressure of primary circuit and without installing an auxiliary pump. It has been manufactured in order to feed hydraulic remote control or to adjust other equipment such as pumps and motors. It works by means of direct pressure reducing valves and it is usually provided with an accumulator in order to ensure, at any time, a certain number of moves even if the primary circuit is in a condition of emergency of failure: it is also used to increase the switching efficiency. In order to avoid the accumulator depletion, the circuit that works at low pressure is protected by an adjustable main relief valve connected in the supply unit and by a check valve.

QUICK REFERENCE GUIDE

Type	Description	Number inlets	Inlet pressure (bar)	Oil input capacity (l/min)	Weight (kg)	Standard threads
SU2	 Two lines supply unit at high pressure	2	350	12	1,7	G 1/4 9/16"18 UNF
SU3	 Three lines supply unit at high pressure	3	350	12	2,0	G 1/4 9/16"18 UNF
SE2	 Supply unit with 2 inlets at high pressure and 1 outlet with reduced pressure with dump valve	2	350	12	2,6	G 1/4 9/16"18 UNF
SE3/1 VPE	 Supply unit with 3 inlets at high pressure and 1 outlet with reduced pressure with dump valve	3	350	12	2,9	G 1/4 9/16"18 UNF
SE3/2 VPE	 Supply unit with 3 inlets at high pressure and 2 outlets with reduced pressure with dump valve on each outlet	3	350	12	4,9	G 1/4 9/16"18 UNF
SE3/3 VPE	 Supply unit with 3 inlets at high pressure and 3 outlets with reduced pressure with dump valve on each outlet	3	350	12	6,0	G 1/4 9/16"18 UNF



GENERAL SPECIFICATIONS

Description	Value
Maximum input pressure	350 bar - 5000 PSI
Pressure on U port line	10 / 70 bar - 145 / 1000 PSI
Maximum back pressure on tank line	3 bar - 43,5 PSI
Minimum pressure in P1	< 1 bar - < 14,5 PSI
Hydraulic fluid	Mineral oil HL, HM (o HLP DIN 51524)
Fluid temperature range	-20°C / +80°C
Fluid viscosity range	10 ÷ 300 cSt
Max contamination level	9 (NAS 1638) - 20/18/15 (ISO 4406:1999)
Recommended filtration	$\beta_{10} > 75$ (ISO 16889:2008)
Accumulator precharge pressure	10 bar - 145 PSI
Maximum working pressure accumulator	210 bar - 3000 PSI
Maximum allowed pressure ratio	$\leq 6/1$
Capacity on service port U (without accumulator)	8 l/min - 2 GPM
Weight accumulator (0,35 l)	3 kg
Weight accumulator (0,75 l)	2,5 kg
Weight accumulator (1,50 l)	5,7 kg
Body material	Cast iron
Surface coating	Zinc plated (International standards 2000/53/CE RoHS)

Because of the small dimensions and working on the same adjusting screw, this valve has the possibility of setting both the pressure reducing valve and the main relief valve. Main relief valve pressure setting is higher than about 10 bar if compared to the pressure reducing valve - see the pressure setting diagram. Supply unit may be installed in any mounting position but the accumulator should be as far as possible from heat sources.

OPERATING PRINCIPLE

The purpose of supply unit SU and SE is to fit hydraulic remote controls in an hydraulic system working at high pressure with reduced flow at a low pressure. Operating principle is that of a direct acting pressure reducing valve. High pressure fluid from the main circuit is routed through ports P1, P2 and P3: pressure is decreased to the value required for supplying the hydraulic controls by means of a pressure reducing valve that directs the necessary fluid to the control via port (U). Supply units are fitted with an accumulator that satisfies short term peak power demands and is a source of emergency power should the main circuit pressure fail. To avoid the accumulator discharge, low pressure circuit is protected both by the adjustable main relief valve inside the cartridge of the pressure reducing valve and by the check valve. To start the hydraulic system, a backpressure of at least 10 bar on service port (P) has to be applied when the accumulator is discharged.

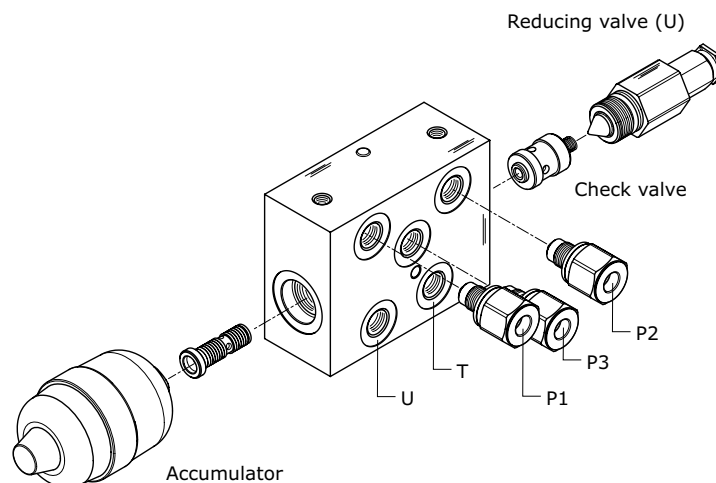



STANDARD LAYOUT DRAWINGS

HYDRAULIC REMOTE CONTROL INPUT WITH AUXILIARY PUMP

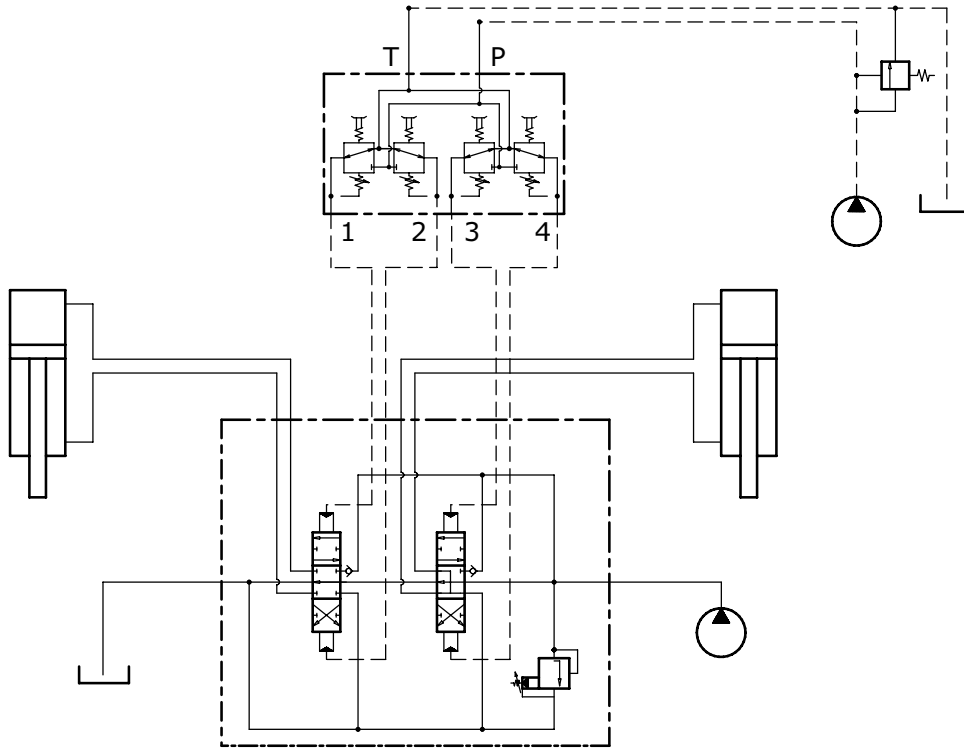

HYDRAULIC REMOTE CONTROL INPUT WITH SUPPLY UNIT COMING FROM THE MAIN CIRCUIT

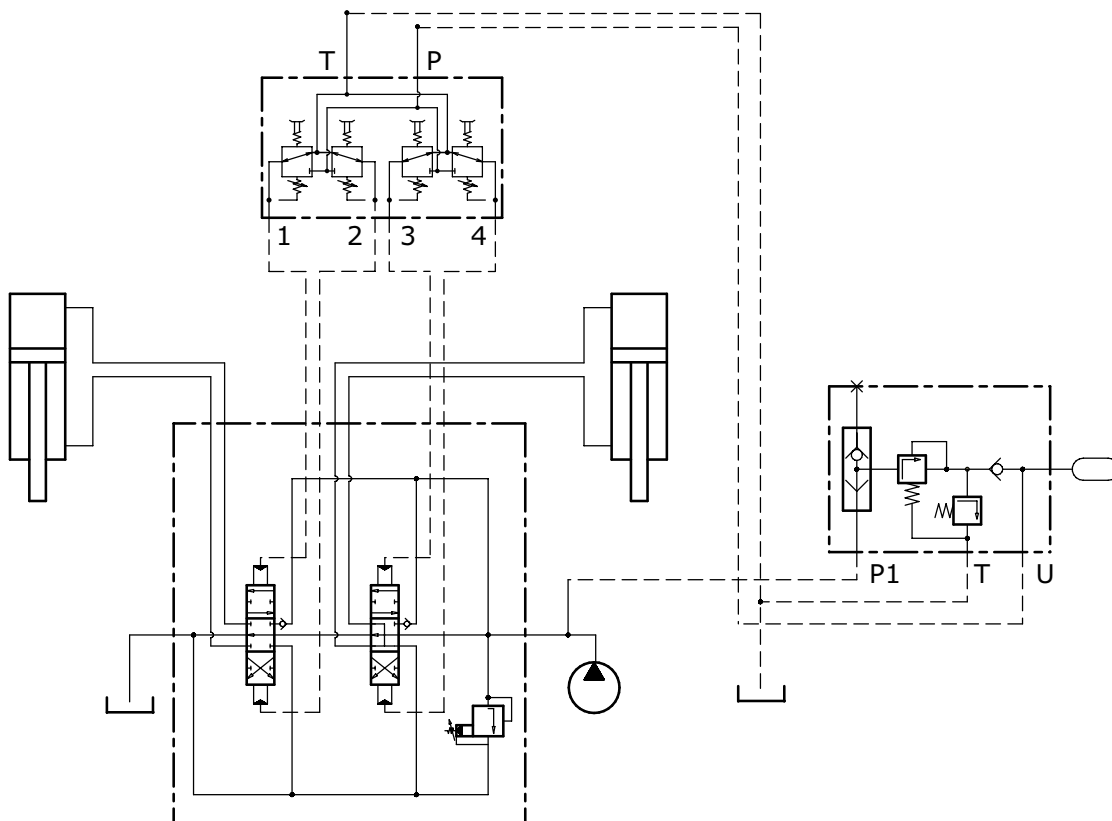

**THREAD CODES**

Ports dimensions are indicated by an ordering code, common throughout the range of remote control made by Hydrocontrol. The following tables highlight the available threads.

BSP - THREAD		
G02	G 1/4	ISO 228-1 / ISO 1179-1

UN / UNF - THREAD		
U02	9/16 - 18 (SAE 6)	ISO 725 / ISO 11926-1

All information and diagrams in this catalogue refer to a mineral base oil VG46 at 50°C temperature (32 cSt kinematic viscosity).



RCX 2 AXIS SINGLE LEVER REMOTE CONTROL

Hydraulic remote control RCX belongs to wide range of Hydrocontrol'e Remote Control; the lever's anti-swaying system and the ergonomic handle provides great sensitivity while manoeuvring and makes his use very comfortable for the operator. Low operating efforts, low energy consumption and low maintenance make these hydraulic remote controls RCX ideal for piloting remote control directional valves, variable displacement pumps and motors, auxiliary valves, frictions and hydraulic brakes.



TECHNICAL SPECIFICATIONS

Max pressure: **100 bar**

Oil capacity: **12 l/min**

Weight: **2,5 Kg**

APPLICATIONS

Mini-excavators, Mini steer loaders, Backhoe loaders, Wheel loaders, Tractors, Boom mower

DIMENSIONS

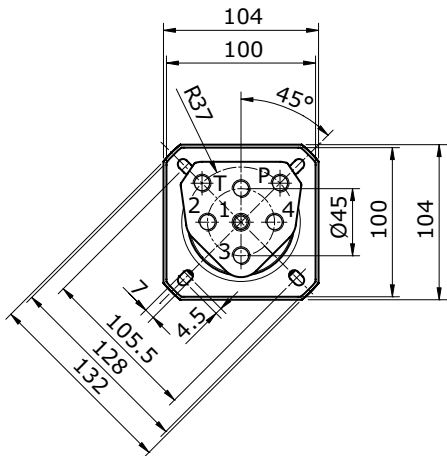

HYDRAULIC SCHEMA

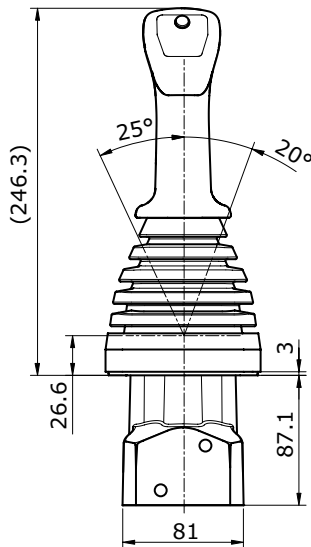
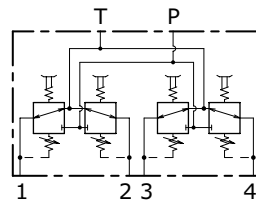

HOLDER HOLE DIMENSION

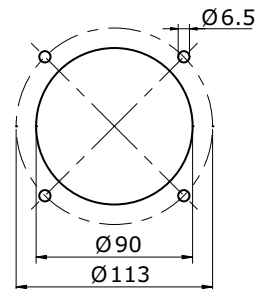



2 AXIS SINGLE LEVER REMOTE CONTROL **RCX**

ORDER EXAMPLE = **RCX: 03 - A01 - MA - F 05F 00R (2) - WF53 - RA G02**

- RCX: product type
- 1 CONTROL CLASSIFICATION:**
 - 03** control type
 - 2 METERING CURVE:**
 - A01** curve type
 - 3 RETURN SPRING:**
 - MA** return spring type
 - 4 HANDLE CLASSIFICATION:**
 - F** handle type
 - 05F** front buttons arrangement
 - 00R** rear buttons arrangement
 - (2)** handle position compared to ports
 - 5 LEVER ROD CLASSIFICATION:**
 - WF** lever rod type
 - 53** lever rod length
 - 6 BODY ARRANGEMENT:**
 - RA** body specification
 - G02** body thread

Ordering row 2 and 3, must be repeated for each port
 complete sample: **RCX: 03 A01 MA A01 MA A01 MA A01 MA F 05F 00R 2 WF53 RA G02**

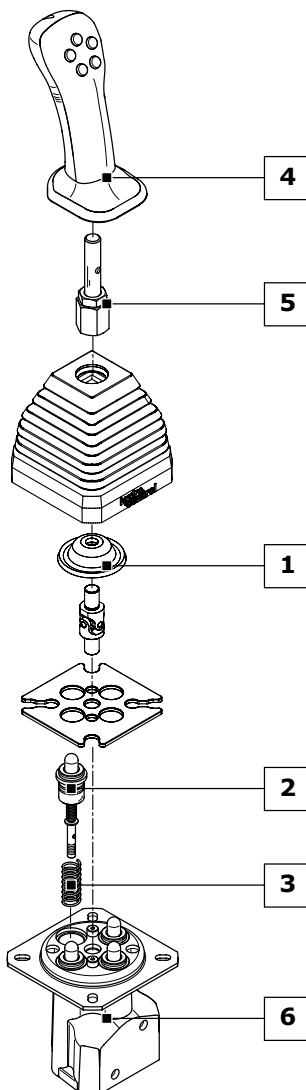

1	CONTROL CLASSIFICATION: (page 12)
01	Return spring in neutral
02	Return spring in neutral with detent in only one service port
03	Return spring in neutral with square bellows for straight lever rod
04	Return spring in neutral with square bellows for bent lever rod
2	METERING CURVE: (page 70)
A01	Linear metering curve with step
B01	Linear metering curve without step
C01	Broken line metering curve with step
D01	Broken line metering curve without step
3	RETURN SPRING: (page 79)
MA	Preload 25 N - End stroke load 48 N
MB	Preload 14 N - End stroke load 27 N
MC	Preload 73 N - End stroke load 135 N
MD	Preload 89 N - End stroke load 169 N
4	HANDLE CLASSIFICATION: (page 80)
A	Without micro-switch
B	With micro-switch to close
D	With dual micro-switch
F	Ergonomic handle
K	Spherical handle
5	LEVER ROD CLASSIFICATION: (page 13)
WF53	Straight standard lever for "F" handle
WG51	Bented standard lever for "F" handle
6	BODY ARRANGEMENT: (page 15)
RA G02	Standard Body (G 1/4 ports)
RB G02	Body with shuttle valve for translation (G 1/4 ports)



RCX 2 AXIS SINGLE LEVER REMOTE CONTROL

CONTROL KIT CLASSIFICATION

All controls installed on the remote control RCX are interchangeable. Lever rod type must be chosen according to different control kit (see quick reference guide pag.13-14). The controls shown correspond to standard configurations; for different applications contact our Commercial Dept.

Code	Configuration	Dimensions	Description
03			Return spring in neutral with square bellows for straight lever rod
04			Return spring in neutral with square bellows for bent lever rod
01			Return spring in neutral with round bellows
02			Return spring in neutral with detent in only one service port NOTE: user port where to apply mechanical detent must be specified



LEVER ROD CLASSIFICATION

The lever rod kits applied to all the RCX hydraulic remote controls designed by Hydrocontrol change according to the type of control used and, above all, the type of handle. For improved clarity, all the possible lever rod configurations divided according to handle are listed here below. Straight and curved lever rods are available in several lengths and dimensions.

IDENTIFICATION ROD LEVER HANDLE "A-B-C-D" - QUICK REFERENCE GUIDE					
Code	Dimensional drawing	Control 01	Control 02	Control 03	Control 04
WA27		•	•		
WB52		•	•		
WD32		•	•		

IDENTIFICATION ROD LEVER HANDLE "F" - QUICK REFERENCE GUIDE					
Code	Dimensional drawing	Control 01	Control 02	Control 03	Control 04
WF53		•	•	•	
WG51		•	•		•
WH48		•	•		•



RCX 2 AXIS SINGLE LEVER REMOTE CONTROL

IDENTIFICATION ROD LEVER HANDLE "K" - QUICK REFERENCE GUIDE

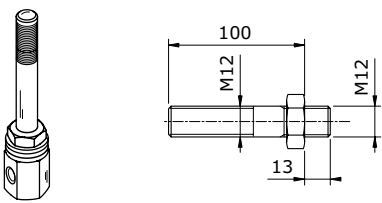
Code	Dimensional drawing	Control 01	Control 02	Control 03	Control 04
WE100		•	•		

IDENTIFICATION ROD LEVER HANDLE "S" - QUICK REFERENCE GUIDE

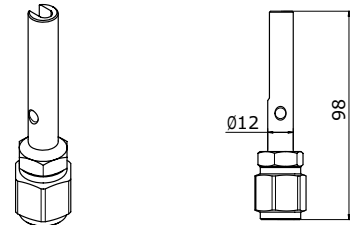
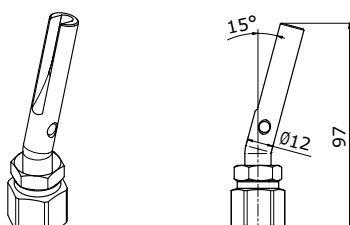
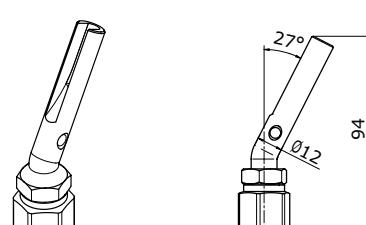
Code	Dimensional drawing	Control 01	Control 02	Control 03	Control 04
WS76		•	•	•	
WT69		•		•	•
WU65		•		•	•



2 AXIS SINGLE LEVER REMOTE CONTROL **RCX**

BODY ARRANGEMENT

The remote hydraulic RCX body has two versions: standard body and body with shuttle valve for translation. The set-up for translation applications (code: RB) includes a flanged plate with internal shuttle valves allowing a single service port control to be split between two ports. In this way, action on the lever will generate two separate pressure signals, allowing dedicated machine translation devices to be controlled.

Code	Configuration	Dimensions	Schema	Description
RA G02				Standard body with ports G 1/4
RA U02				Standard body with ports 9/16" - 18 UNF
RB G02				Body with shuttle valve for translation with ports G 1/4
RB U02				Body with shuttle valve for translation with ports 9/16" - 18 UNF
RB01 G02				Body with shuttle valve for translation with auxiliary port (X) for Alert with ports G 1/4
RB01 U02			 (*) Chokes \varnothing 2 mm on ports 1 - 3	Body with shuttle valve for translation with auxiliary port (X) for Alert with ports 9/16" - 18 UNF

As an alternative to the "RB01" version, other set-ups are available with different flow restrictor diameters and configurations on the service ports; for more information contact our Commercial Dept.



RCY 2 AXIS SINGLE LEVER REMOTE CONTROL REDUCED OPERATING FORCE

The new RCY hydraulic remote control is an evolution of the RCX model. It adds to the variety of options and solutions offered by RCX with an upgraded hydraulic control system, allowing the operating comfort to be improved; the reduced-diameter control spool allows the required operating effort to be reduced by approximately 30%, without affecting the control, hysteresis and accuracy characteristics of this device.



TECHNICAL SPECIFICATIONS

Max pressure: **100 bar**

Oil capacity: **12 l/min**

Weight: **2,5 Kg**

APPLICATIONS

Mini-excavators, Mini steer loaders, Backhoe loaders, Wheel loaders, Tractors, Boom mower

DIMENSIONS

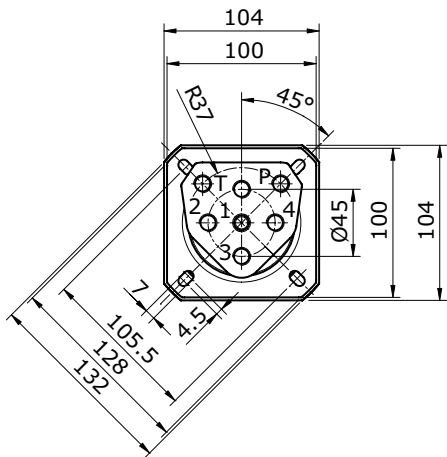

HYDRAULIC SCHEMA

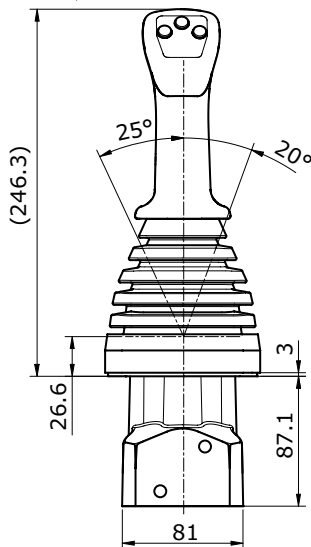
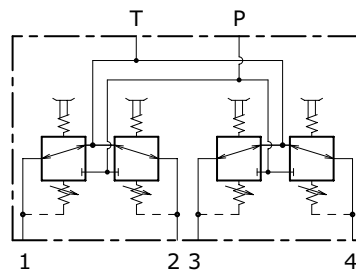

HOLDER HOLE DIMENSION

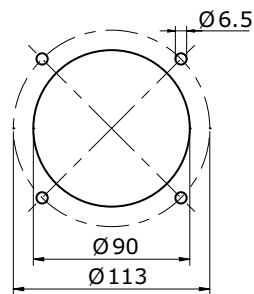



2 AXIS SINGLE LEVER REMOTE CONTROL REDUCED OPERATING FORCE **RCY**

ORDER EXAMPLE = **RCY: 03 - A01 - MB - F 03F 00R (2) - WF53 - RA G02**

- RCY product type _____
- 1) CONTROL CLASSIFICATION:** _____
- 03** control type
- 2) METERING CURVE:** _____
- A01** curve type
- 3) RETURN SPRING:** _____
- MB** return spring type
- 4) HANDLE CLASSIFICATION:** _____
- F** handle type
- 03F** front buttons arrangement
- 00R** rear buttons arrangement
- (2)** handle position compared to ports
- 5) LEVER ROD CLASSIFICATION:** _____
- WF** lever rod type
- 53** lever rod length
- 6) BODY ARRANGEMENT:** _____
- RA** body specification
- G02** body thread

Ordering row 2 and 3, must be repeated for each port

complete sample: **RCY: 03 A01 MB A01 MB A01 MB A01 MB F 03F 00R 2 WF53 RA G02**

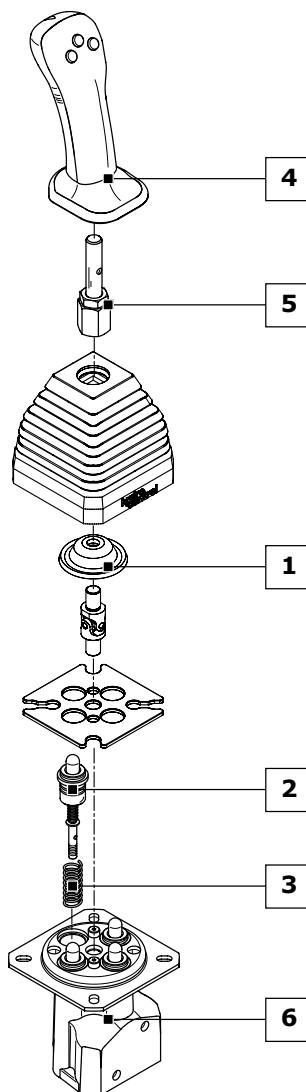

1	CONTROL CLASSIFICATION: (page 14)
01	Return spring in neutral
02	Return spring in neutral with detent in only one service port
03	Return spring in neutral with square bellows for straight lever rod
04	Return spring in neutral with square bellows for bent lever rod
2	METERING CURVE: (page 75)
A01	Linear metering curve with step
B01	Linear metering curve without step
C01	Broken line metering curve with step
D01	Broken line metering curve without step
3	RETURN SPRING: (page 79)
MA	Preload 25 N - End stroke load 48 N
MB	Preload 14 N - End stroke load 27 N
MC	Preload 73 N - End stroke load 135 N
MD	Preload 89 N - End stroke load 169 N
4	HANDLE CLASSIFICATION: (page 80)
A	Without micro-switch
B	With micro-switch to close
D	With dual micro-switch
F	Ergonomic handle
K	Spherical handle
5	LEVER ROD CLASSIFICATION: (page 13)
WF53	Straight standard lever for "F" handle
WG51	Bented standard lever for "F" handle
6	BODY ARRANGEMENT: (page 15)
RA G02	Standard Body (G 1/4 ports)
RB G02	Body with shuttle valve for translation (G 1/4 ports)



RCL 2 AXIS SINGLE LEVER REMOTE CONTROL WITH ELECTROMAGNETIC DETENT

RCL is a remote control specifically designed for Wheel Loaders application. Based on the design of RCX, it is used for two axis control (typically boom and bucket). It includes the function of electromagnetic detent to hold the lever at the end of the stroke: this feature is requested on loaders to allow the operator to start driving while boom and bucket functions are still moving.



TECHNICAL SPECIFICATIONS

Max pressure: **40 bar**

Oil capacity: **12 l/min**

Weight: **2,9 Kg**

APPLICATIONS

Wheel loaders, Skid steer loader

DIMENSIONS

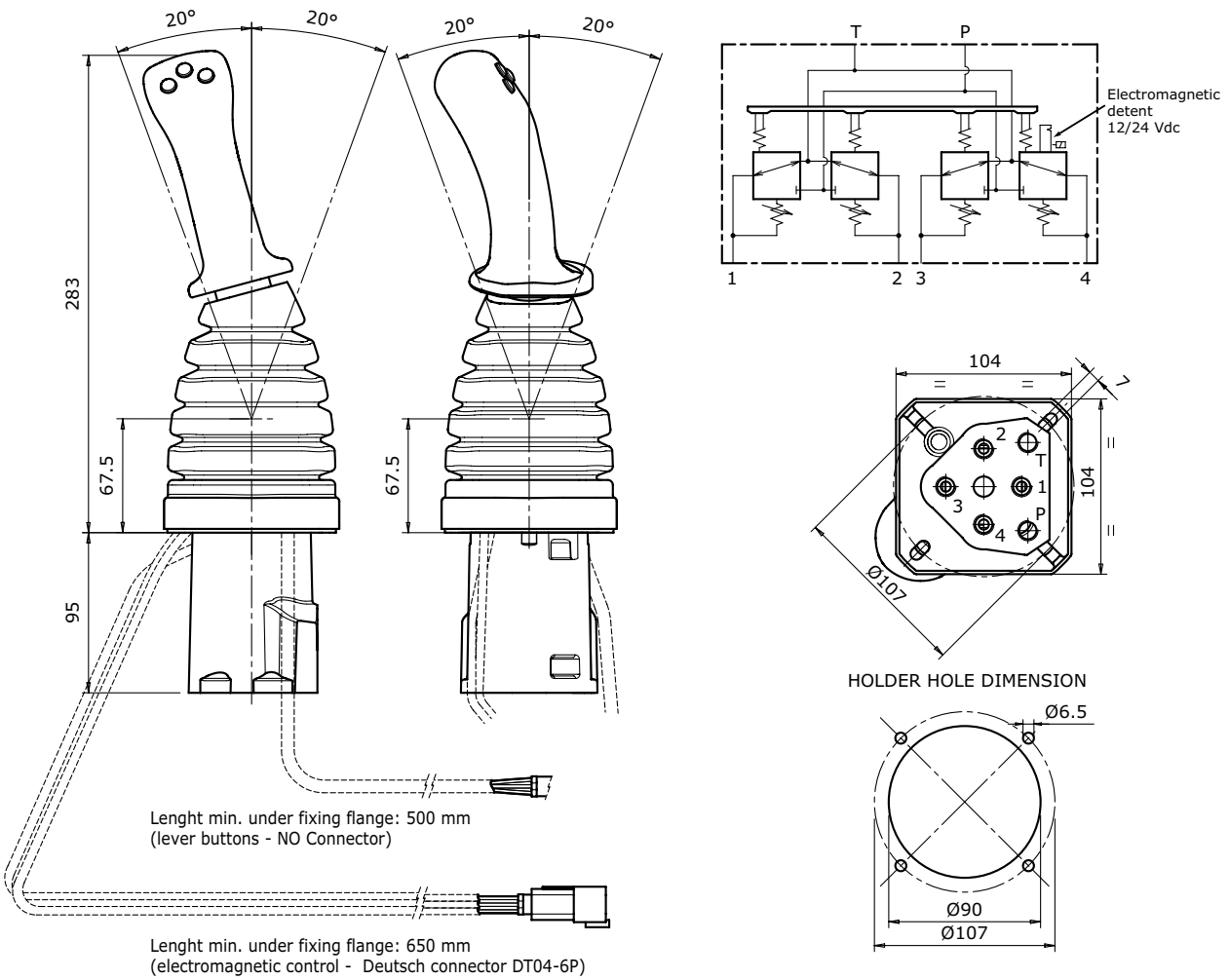



2 AXIS SINGLE LEVER REMOTE CONTROL WITH ELECTROMAGNETIC DETENT

RCL

ELECTROMAGNETIC DETENT TECHNICAL SPECIFICATION

Description	Value
Supply voltage	12 Vdc +/-20% - 24 Vdc +/-20%
Resistance at 20°C	22W - 94W
Power at 20°C	7W
Duty rating	ED100%
Coil insulation class (IEC 85)	H
Connector	Deutsch DT04-6P
Connector protection (EN 60529)	IP67

A 6-pole Deutsch DT04-6P connector is always used notwithstanding the number of required electromagnetic detents. The drawing here below shows the wiring of the solenoids assembled on the service ports 2, 3 and 4. The Deutsch DT06-6S connector counterpart can be supplied on request by quoting the order code 487200906.

Deutsch Connector (DT04-6P)

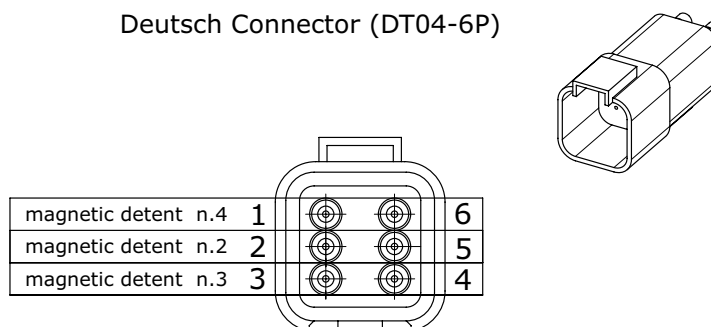



RCL3 2 AXIS LEVER + SINGLE AXIS LEVER REMOTE CONTROL WITH ELECTROMAGNETIC DETENT

RCL3 is a remote control specifically designed for Wheel Loaders application. The compact design combines in a single body the two axis control (for boom and bucket) with a third axis (for auxiliary function). Electromagnetic detent is available on all ports. A security electrovalve to activate the remote control is available on request.



TECHNICAL SPECIFICATIONS

Max pressure: **40 bar**

Oil capacity: **12 l/min**

Weight: **4,8 Kg**

APPLICATIONS

Wheel loaders

DIMENSIONS

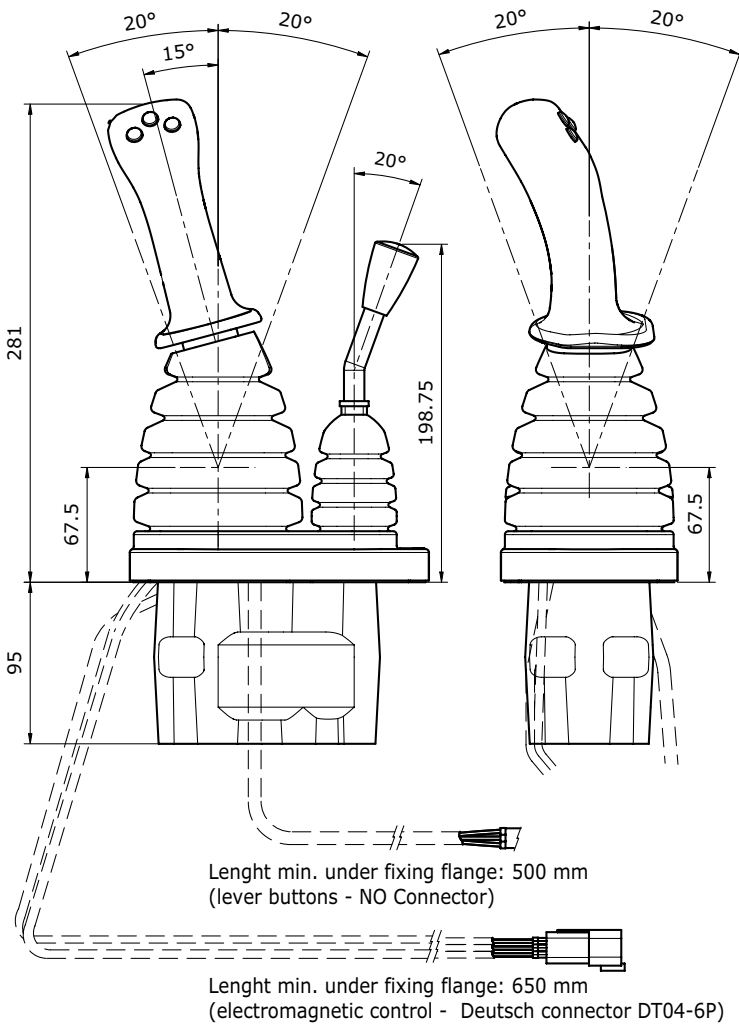

HYDRAULIC SCHEMA

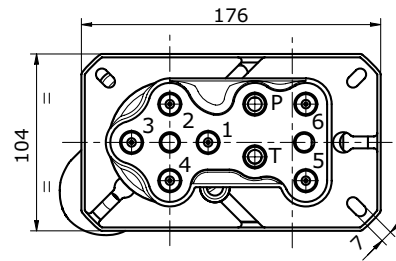
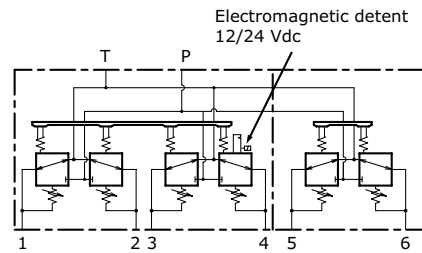

HOLDER HOLE DIMENSION

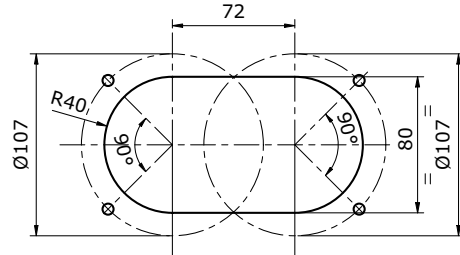



2 AXIS LEVER + SINGLE AXIS LEVER REMOTE CONTROL WITH ELECTROMAGNETIC DETENT

RCL3

ELECTROMAGNETIC DETENT TECHNICAL SPECIFICATION

Description	Value
Supply voltage	12 Vdc +/-20% - 24 Vdc +/-20%
Resistance at 20°C	22W - 94W
Power at 20°C	7W
Duty rating	ED100%
Coil insulation class (IEC 85)	H
Connector	Deutsch DT04-6P
Connector protection (EN 60529)	IP67

A 6-pole Deutsch DT04-6P connector is always used notwithstanding the number of required electromagnetic detents. The drawing here below shows the wiring of the solenoids assembled on the service ports 2, 3 and 4. The Deutsch DT06-6S connector counterpart can be supplied on request by quoting the order code 487200906.

Deutsch Connector (DT04-6P)

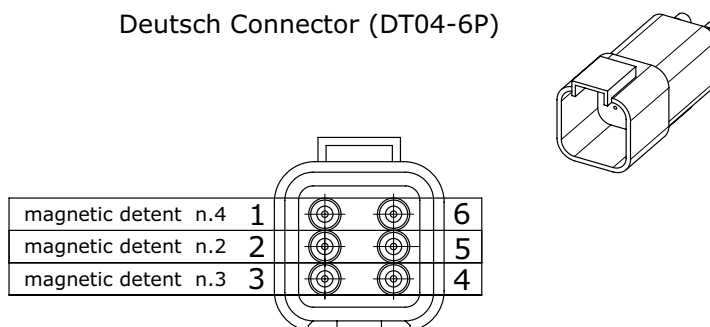

OPTIONS

The single-axis remote control is available without any detents, with electromagnetic detent or with mechanical detent.



RCM STACKABLE SINGLE AXIS LEVER REMOTE CONTROL

Hydraulic remote control RCM belongs to the wide range of Hydrocontrol products. Low operating efforts, low energy consumption and low maintenance make these hydraulic remote controls RCM ideal for piloting remote control directional valves, variable displacement pumps and motors, auxiliary valves, frictions and hydraulic brakes. Each hydraulic remote control is assembled with N.2 tie rod kits which include a tie rod, two nuts and two washers. It can be assembled up to 12 working sections.



TECHNICAL SPECIFICATIONS

Working section number: **1 - 12**

Max pressure: **60 bar**

Oil capacity: **12 l/min**

Weight RCM/1: **1,5 Kg**

Tie rod clamping torque: **14 Nm**

APPLICATIONS

Mini steer loaders, Backhoe loaders, Tractors

DIMENSIONS

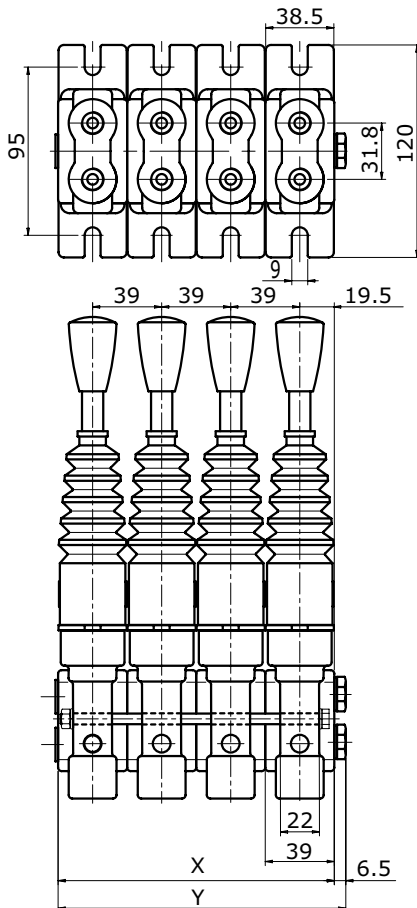

HYDRAULIC SCHEMA

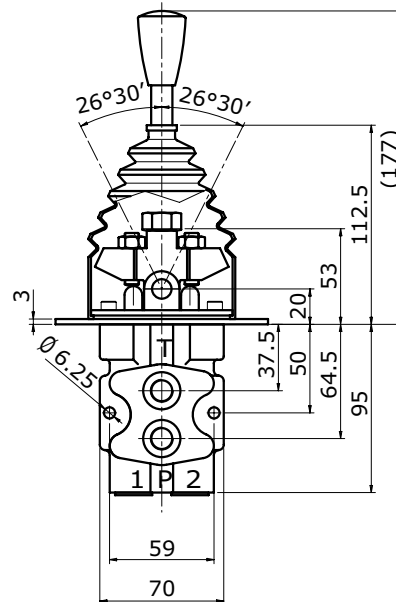
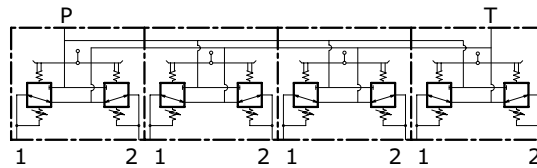

TYPE	/1	/2	/3	/4	/5	/6	/7	/8	/9	/10	/11	/12
X (mm)	39	78	117	156	195	234	273	312	351	390	429	468
Y (mm)	45,5	84,4	123,5	162,5	201,5	240,5	279,5	318,5	357,5	396,5	435,5	474,5
Weights (kg)	1,5	3	4,5	6	7,5	9	10,5	12	13,5	15	16,5	18



STACKABLE SINGLE AXIS LEVER REMOTE CONTROL **RCM**

ORDER EXAMPLE = RCM/1: 01 - A01 - MA - M - WE95 - RA G02

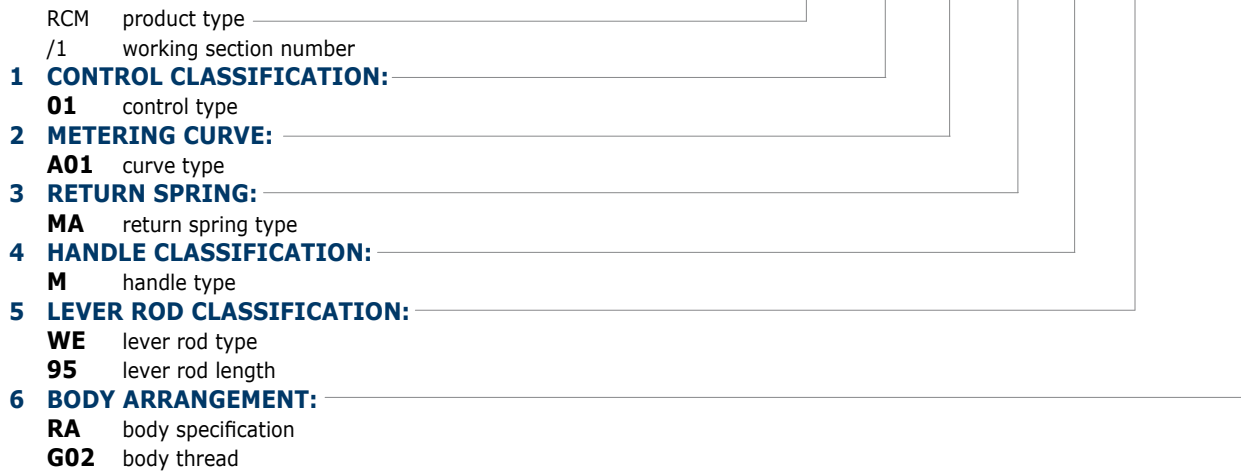

Ordering row 2 and 3, must be repeated for each port
 complete sample: **RCM/1: 01 A01 MA A01 MA A01 M WE95 RA G02**

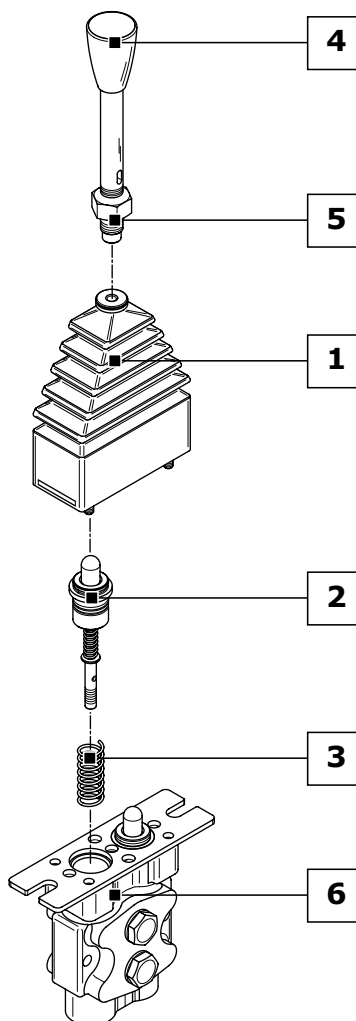

1	CONTROL CLASSIFICATION: (page 24)
01	Return spring in neutral
02	Stroke end mechanical detent in position 1 and 2
03	Stroke end mechanical detent in position 1
04	Stroke end mechanical detent in position 2
2	METERING CURVE: (page 70)
A01	Linear metering curve with step
B01	Linear metering curve without step
C01	Broken line metering curve with step
D01	Broken line metering curve without step
3	RETURN SPRING: (page 79)
MA	Preload 25 N - End stroke load 48 N
MB	Preload 14 N - End stroke load 27 N
MC	Preload 73 N - End stroke load 135 N
MD	Preload 89 N - End stroke load 169 N
4	HANDLE CLASSIFICATION: (page 80)
A	Without micro-switch
B	With micro-switch to close
D	With dual micro-switch
M	Standard handle
5	LEVER ROD CLASSIFICATION: (page 26)
WE95	Standard lever for "M" handle (95 mm)
WE165	Standard lever for "M" handle (165 mm)
6	BODY ARRANGEMENT: (page 27)
RA G02	Standard Body (G 1/4 ports)
RA U02	Standard Body (9/16"-18 UNF ports)



RCM STACKABLE SINGLE AXIS LEVER REMOTE CONTROL

CONTROL KIT CLASSIFICATION

All controls installed on the remote control RCM are interchangeable. Lever rod type must be chosen according to different control kit (see quick reference guide pag. 27). The controls shown correspond to standard configurations; for different applications contact our Commercial Dept.

Code	Configuration	Schema	Description
01			Return spring in neutral
02			Stroke end mechanical detent in position 1 and 2
03			Stroke end mechanical detent in position 1
04			Stroke end mechanical detent in position 2
19			Return spring in neutral with micro-switch open in central position
31			Return spring in neutral with micro-switch closed in central position



STACKABLE SINGLE AXIS LEVER REMOTE CONTROL **RCM**

Code	Configuration	Schema	Description
25			Security handle in neutral
17			Security handle in neutral with micro-switch closed in central position
12			Security handle in neutral with micro-switch open in central position
26			Friction
18			Friction with micro-switch closed in central position
13			Friction with micro-switch open in central position
27			Friction and security handle in neutral





RCM STACKABLE SINGLE AXIS LEVER REMOTE CONTROL

MICROSWITCHES SPECIFICATIONS

Description	Value
Direct current load resistive	5 A / 30 Vdc
Direct current load inductive	3 A / 250 Vac
Alternative current load resistive	5 A / 30 Vdc
Alternative current load inductive	2 A / 250 Vac

LEVER ROD CLASSIFICATION

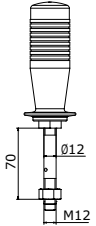
The lever rod kits applied to all the RCM hydraulic remote controls designed by Hydrocontrol change according to the type of control used and, above all, the type of handle. For improved clarity, all the possible lever rod configurations divided according to handle are listed here below. Straight and curved lever rods are available in several lengths and dimensions.

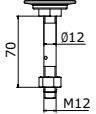
IDENTIFICATION ROD LEVER HANDLE "A-B-C-D" - QUICK REFERENCE GUIDE														
Code	Dimensional drawing	Control type												
		01	02	03	04	12	13	17	18	19	25	26	27	31
WA70			•	•	•	•		•		•	•			•
WQ70 (only for "A" handle)													•	

Handles type "A-B-C-D" are only available with RCM/1. To set up an RCM remote control with any number of sections between 2 and 12, an intermediate plate must be used identified by the order code RP.

ORDER EXAMPLE RCM/3 WITH "RP" INTERMEDIATE PLATE

RCM/3: 01-A01-MA-A WA70-RA G02 - **RP** - 01-A01-MA-A WA70-RA G02 - **RP** - 01-A01-MA-A WA70-RA G02

- 1) FIRST SECTION: _____
- 2) **INTERMEDIATE PLATE:** _____
- 3) SECOND SECTION: _____
- 4) **INTERMEDIATE PLATE:** _____
- 5) THIRD SECTION: _____

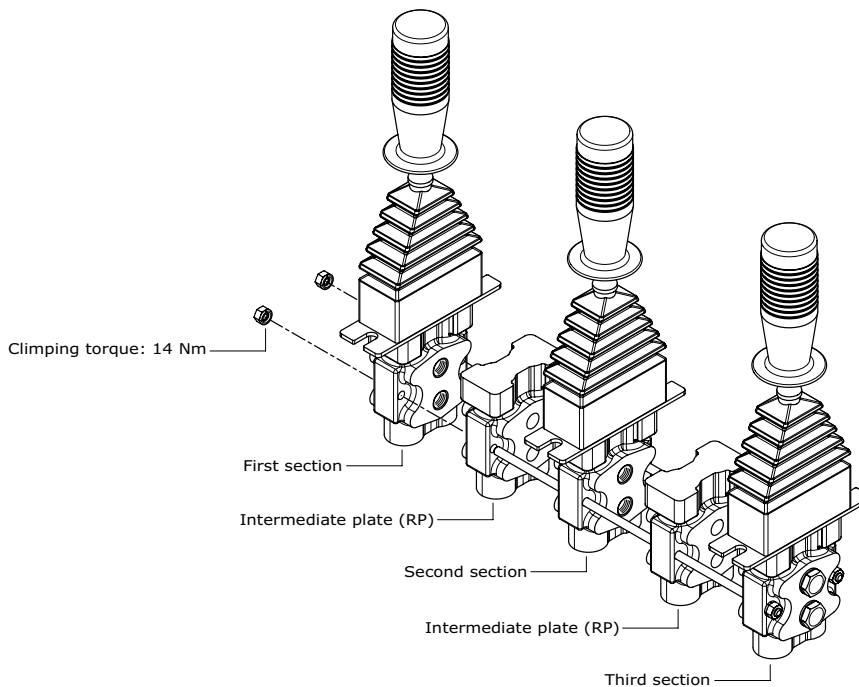



STACKABLE SINGLE AXIS LEVER REMOTE CONTROL **RCM**

IDENTIFICATION ROD LEVER HANDLE "M" - QUICK REFERENCE GUIDE														
Code	Dimensional drawing	Control type												
		01	02	03	04	12	13	17	18	19	25	26	27	31
WE95		•	•	•	•		•		•	•				•
WE165		•	•	•	•		•		•	•				•
WM95							•		•					
WM165							•		•					
WN95													•	•
WR95														•

BODY ARRANGEMENT

The hydraulic remote control RCM has only one setting body, the only variable is represented by a different thread.

Code	Configuration	Schema	Description
RA G02			Standard body with ports G 1/4
RA U02			Standard body with ports 9/16" - 18 UNF



RCB SINGLE AXIS LEVERS TWO MODULES REMOTE CONTROL

Hydraulic remote control RCB belongs to the wide range of Hydrocontrol. Low operating efforts, low energy consumption and low maintenance makes these hydraulic remote controls RCB ideals for piloting remote control directional valves, variable displacement pumps and motors, auxiliary valves, frictions and hydraulic brakes. Each hydraulic remote control is assembled with N.2 tie rod kits including a tie rod, two nuts and two washers.



TECHNICAL SPECIFICATIONS

Working section number:	2
Max pressure:	60 bar
Oil capacity:	12 l/min
Weight:	3,2 Kg
Tie rod clamping torque:	14 Nm

APPLICATIONS

Mini skid loaders, Backhoe loaders, Tractors

DIMENSIONS

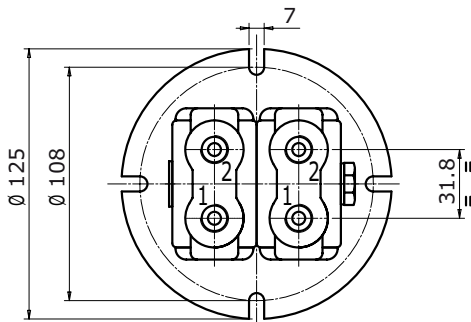

HYDRAULIC SCHEMA

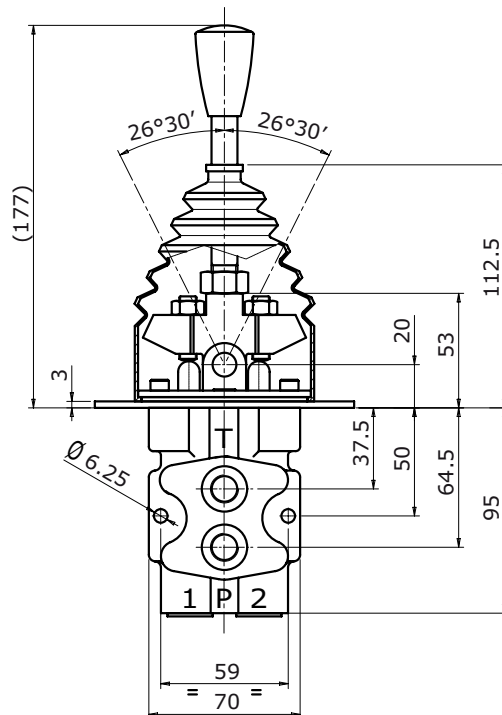
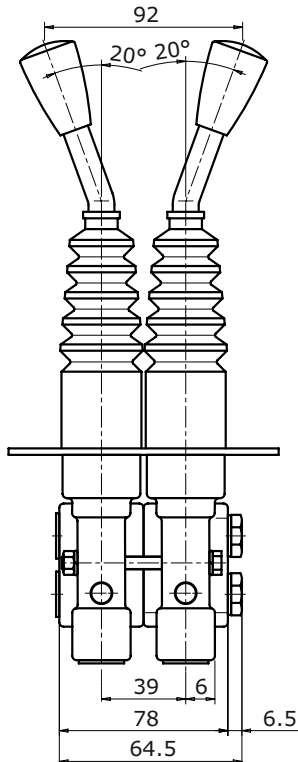
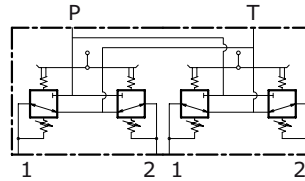



SINGLE AXIS LEVERS TWO MODULES REMOTE CONTROL **RCB**

	SECTION 1	SECTION 2
ORDER EXAMPLE = RCB: 01 A01 MA M WP110 - 01 A01 MA M WP110 - RA G02		
RCB	product type	
1 CONTROL CLASSIFICATION:		
01	control type	
2 METERING CURVE:		
A01	curve type	
3 RETURN SPRING:		
MA	return spring type	
4 HANDLE CLASSIFICATION:		
M	handle type	
5 LEVER ROD CLASSIFICATION:		
WP	lever rod type	
110	lever rod length	
6 BODY ARRANGEMENT:		
RA	body specification	
G02	body thread	

Ordering row 1,2,3,4 and 5, must be repeated for each working section

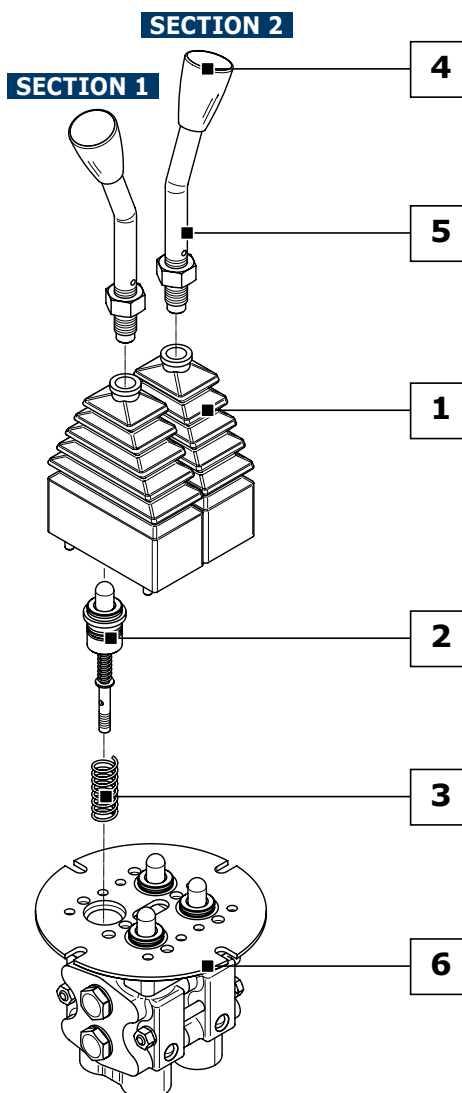

1 CONTROL CLASSIFICATION:	(page 30)
01	Return spring in neutral
02	Stroke end mechanical detent in position 1 and 2
03	Stroke end mechanical detent in position 1
04	Stroke end mechanical detent in position 2
2 METERING CURVE:	(page 70)
A01	Linear metering curve with step
B01	Linear metering curve without step
C01	Broken line metering curve with step
D01	Broken line metering curve without step
3 RETURN SPRING:	(page 79)
MA	Preload 25 N - End stroke load 48 N
MB	Preload 14 N - End stroke load 27 N
MC	Preload 73 N - End stroke load 135 N
MD	Preload 89 N - End stroke load 169 N
4 HANDLE CLASSIFICATION:	(page 80)
A	Without micro-switch
B	With micro-switch to close
D	With dual micro-switch
M	Standard handle
5 LEVER ROD CLASSIFICATION:	(page 32)
WV75	Standard lever for handle type A-B-C-D (75 mm)
WP110	Standard lever for handle type M (110 mm)
6 BODY ARRANGEMENT:	(page 33)
RA G02	Standard Body (G 1/4 ports)
RA U02	Standard Body (9/16"-18 UNF ports)



RCB SINGLE AXIS LEVERS TWO MODULES REMOTE CONTROL

CONTROL KIT CLASSIFICATION

All controls installed on the remote control RCB are interchangeable. Lever rod type must be chosen according to different control kit (see quick reference guide pag. 32). The controls shown correspond to standard configurations; for different applications contact our Commercial Dept.

Code	Configuration	Schema	Description
01			Return spring in neutral
02			Stroke end mechanical detent in position 1 and 2
03			Stroke end mechanical detent in position 1
04			Stroke end mechanical detent in position 2
05			Security handle in neutral
06			Friction



SINGLE AXIS LEVERS TWO MODULES REMOTE CONTROL

RCB

Code	Configuration	Schema	Description
12			Security handle in neutral with micro-switch open in central position
18			Friction with micro-switch closed in central position

MICROSWITCHES SPECIFICATIONS

description	Value
Direct current load resistive	5 A / 30 Vdc
Direct current load inductive	3 A / 250 Vac
Alternative current load resistive	5 A / 30 Vdc
Alternative current load inductive	2 A / 250 Vac



RCB SINGLE AXIS LEVERS TWO MODULES REMOTE CONTROL

LEVER ROD CLASSIFICATION

The lever rod kits applied to all the RCB hydraulic remote controls designed by Hydrocontrol change according to the type of control used and, above all, the type of handle. For improved clarity, all the possible lever rod configurations divided according to handle are listed here below. Straight and curved lever rods are available in several lengths and dimensions.

IDENTIFICATION ROD LEVER HANDLE "A-B-C-D" - QUICK REFERENCE GUIDE

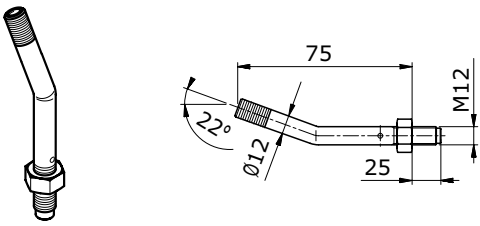
Code	Dimensional drawing	Control type							
		01	02	03	04	05	06	12	18
WV75		•	•	•	•		•		•

IDENTIFICATION ROD LEVER HANDLE "M" - QUICK REFERENCE GUIDE

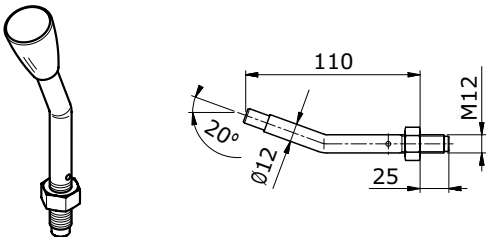
Code	Dimensional drawing	Control type							
		01	02	03	04	05	06	12	18
WP110		•	•	•	•		•		•
WT110						•		•	



SINGLE AXIS LEVERS TWO MODULES REMOTE CONTROL **RCB**

BODY ARRANGEMENT

The hydraulic remote control RCB has only one setting body, the only variable is represented by a different thread.

Code	Configuration	Schema	Description
RA G02			Standard body with ports G 1/4
RA U02			Standard body with ports 9/16" - 18 UNF



RCP FOOT PEDAL 2 SERVICE PORTS WITH SIDE PORTS AND REDUCED BODY HEIGHT

Hydraulic remote control RCP belongs to the wide range of Hydrocontrol S.p.A. This Pedal is characterized by reduced overall dimensions and several configurations. RCP works according to the principle of direct-acting pressure reducing valves. In rest position, the foot pedal is held in neutral by return spring; inlet port P is closed and ports are connected to tank port T.



TECHNICAL SPECIFICATIONS

Max pressure: **100 bar**

Oil capacity: **12 l/min**

Weight: **3,4 Kg**

APPLICATIONS

Mini-excavators

DIMENSIONS

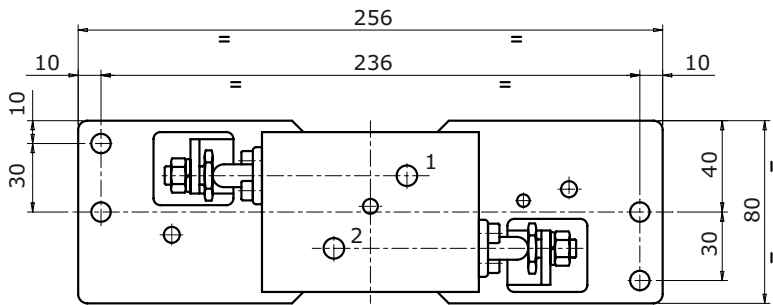

HYDRAULIC SCHEMA

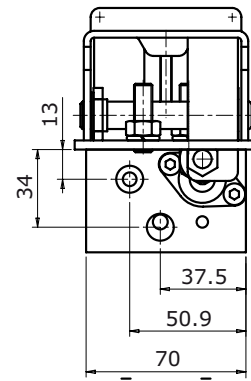
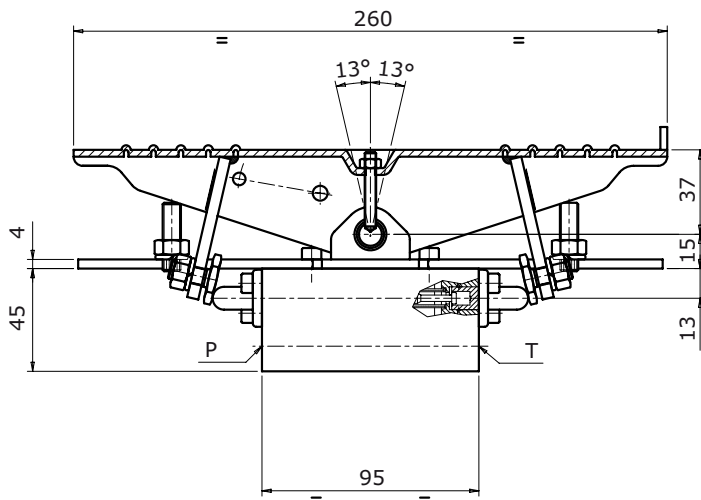
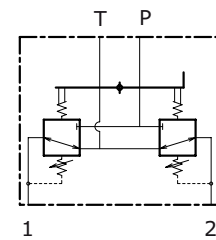



FOOT PEDAL 2 SERVICE PORTS WITH SIDE PORTS AND REDUCED BODY HEIGHT

RCP

ORDER EXAMPLE = RCP: 01S - A01 - MA - RA G02

- RCP product type _____
- 1 CONTROL CLASSIFICATION:** _____
- 01S** control type _____
- 2 METERING CURVE:** _____
- A01** curve type _____
- 3 RETURN SPRING:** _____
- MA** return spring type _____
- 4 BODY ARRANGEMENT:** _____
- RA** body specification _____
- G02** body thread _____

Ordering row 2 and 3, must be repeated for each port
 complete sample: **RCP: 01S A01 MA A01 MA RA G02**

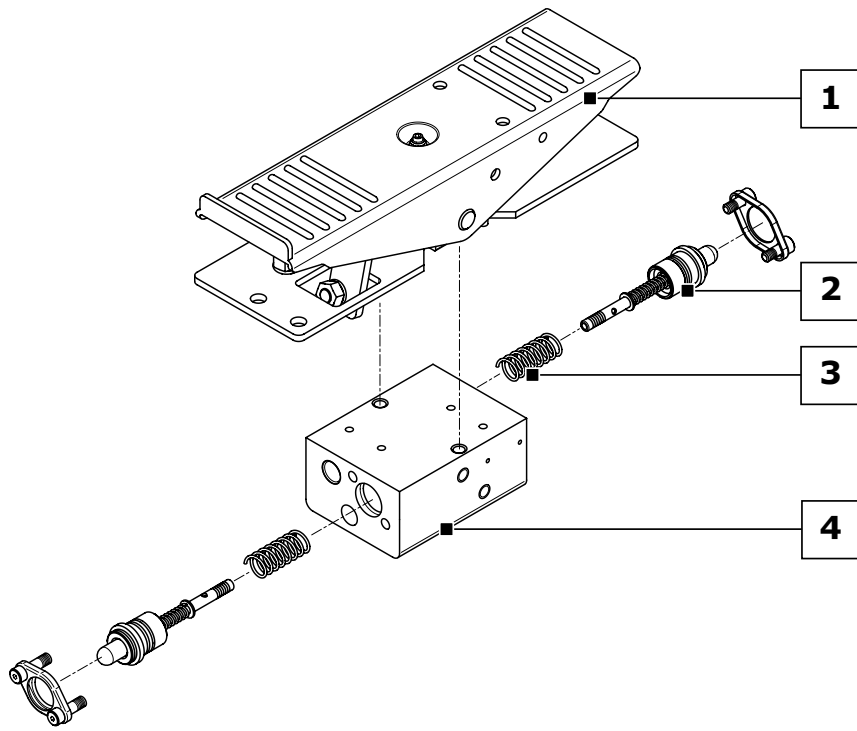

1	CONTROL CLASSIFICATION: (page 36)
01S	Foot pedal with return spring in neutral
02S	Foot pedal with prearranged handle and return spring in neutral
03S	Foot pedal with adjustable angle and prearranged handle and return spring in neutral
04S	Foot pedal with adjustable angle with return spring in neutral
2	METERING CURVE: (page 70)
A01	Linear metering curve with step
B01	Linear metering curve without step
C01	Broken line metering curve with step
D01	Broken line metering curve without step

3	RETURN SPRING: (page 79)
MA	Preload 25 N - End stroke load 48 N
MB	Preload 14 N - End stroke load 27 N
MC	Preload 73 N - End stroke load 135 N
MD	Preload 89 N - End stroke load 169 N
4	BODY ARRANGEMENT: (page 37)
RA G02	Standard Body (G 1/4 ports)
RA U02	Standard Body (9/16"-18 UNF ports)



RCP FOOT PEDAL 2 SERVICE PORTS WITH SIDE PORTS AND REDUCED BODY HEIGHT

CONTROL KIT CLASSIFICATION

All controls installed on the foot pedal RCP are interchangeable. The controls shown correspond to standard configurations; for different applications contact our Commercial Dept.

Code	Configuration	Schema	Description
01S			Foot pedal with return spring in neutral
02S			Foot pedal with prearranged handle and return spring in neutral
03S			Foot pedal with adjustable angle and prearranged handle and return spring in neutral
04S			Foot pedal with adjustable angle with return spring in neutral



FOOT PEDAL 2 SERVICE PORTS WITH SIDE PORTS AND REDUCED BODY HEIGHT

RCP

BODY ARRANGEMENT

The foot pedal RCP has only one setting body, the only variable is represented by a different thread.

Code	Configuration	Schema	Description
RA G02			Standard body with ports G 1/4
RA U02			Standard body with ports 9/16" - 18 UNF



RCF FOOT PEDAL LOWER PORTS

Hydraulic remote control RCF belongs to the wide range of Hydrocontrol S.p.A. This Pedal is characterized by reduced overall dimensions and several configurations. RCF works according to the principle of direct-acting pressure reducing valves. In rest position, the foot pedal is held in neutral by return spring; inlet port P is closed and ports are connected to tank port T. P, T and users ports are under the body, opposite to the pedal.



TECHNICAL SPECIFICATIONS

Max pressure: **100 bar**

Oil capacity: **12 l/min**

Weight: **4,1 Kg**

APPLICATIONS

Mini-excavators

DIMENSIONS

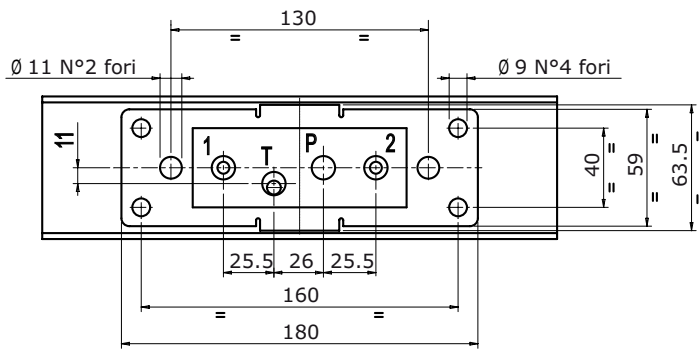

HYDRAULIC SCHEMA

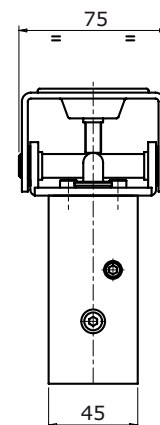
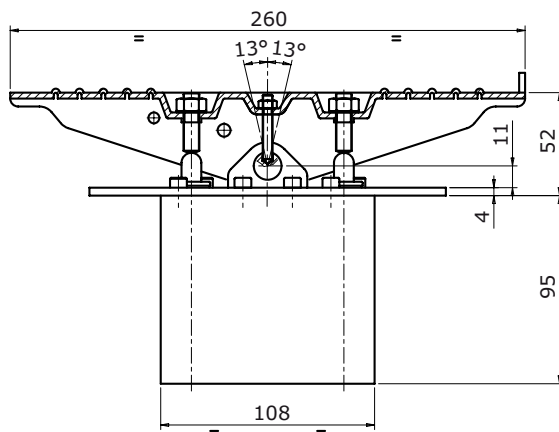
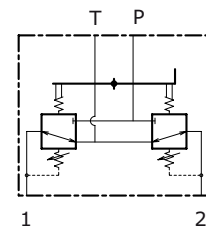



FOOT PEDAL LOWER PORTS **RCF**

ORDER EXAMPLE = RCF: 01S - A01 - MA - RA G02

- RCF product type _____
- 1 CONTROL CLASSIFICATION:** _____
- 01S** control type
- 2 METERING CURVE:** _____
- A01** curve type
- 3 RETURN SPRING:** _____
- MA** return spring type
- 4 BODY ARRANGEMENT:** _____
- RA** body specification
- G02** body thread

Ordering row 2 and 3, must be repeated for each port
 complete sample: **RCF: 01S A01 MA A01 MA RA G02**

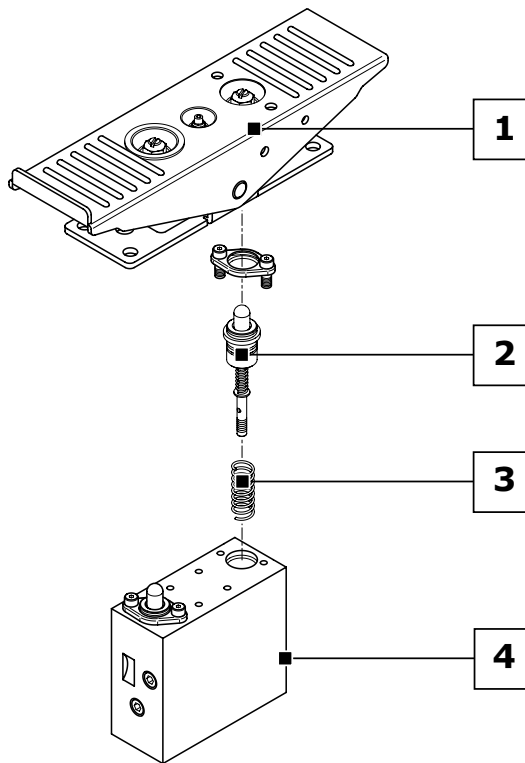

1	CONTROL CLASSIFICATION: (page 40)
01S	Foot pedal with return spring in neutral
02S	Foot pedal with prearranged handle and return spring in neutral
03S	Foot pedal with adjustable angle and prearranged handle and return spring in neutral
04S	Foot pedal with adjustable angle with return spring in neutral
2	METERING CURVE: (page 70)
A01	Linear metering curve with step
B01	Linear metering curve without step
C01	Broken line metering curve with step
D01	Broken line metering curve without step

3	RETURN SPRING: (page 79)
MA	Preload 25 N - End stroke load 48 N
MB	Preload 14 N - End stroke load 27 N
MC	Preload 73 N - End stroke load 135 N
MD	Preload 89 N - End stroke load 169 N
4	BODY ARRANGEMENT: (page 41)
RA G02	Standard Body (G 1/4 ports)
RA U02	Standard Body (9/16"-18 UNF ports)



RCF FOOT PEDAL LOWER PORTS

CONTROL KIT CLASSIFICATION

All controls installed on the foot pedal RCF are interchangeable. The controls shown correspond to standard configurations; for different applications contact our Commercial Dept.

Code	Configuration	Schema	Description
01S			Foot pedal with return spring in neutral
02S			Foot pedal with prearranged handle and return spring in neutral
03S			Foot pedal with adjustable angle and prearranged handle and return spring in neutral
04S			Foot pedal with adjustable angle with return spring in neutral



BODY ARRANGEMENT

The foot pedal RCF has only one setting body, the only variable is represented by a different thread.

Code	Configuration	Schema	Description
RA G02			Standard body with ports G 1/4
RA U02			Standard body with ports 9/16" - 18 UNF



RCD DOUBLE FOOT PEDAL LOWER PORTS

RCD is a double pedal version remote control and belongs to the wide range of Hydrocontrol S.p.A. This pedal work according to the principle of direct-acting pressure reducing valves. In rest position, the foot pedal is held in neutral by return spring; inlet port P is closed and ports are connected to tank port T. Reduced overall dimensions and ergonomic design for a optimal control.



TECHNICAL SPECIFICATIONS

Max pressure: **60 bar**

Oil capacity: **12 l/min**

Weight: **3,2 Kg**

APPLICATIONS

Mini skid loaders, Mini dumper

DIMENSIONS

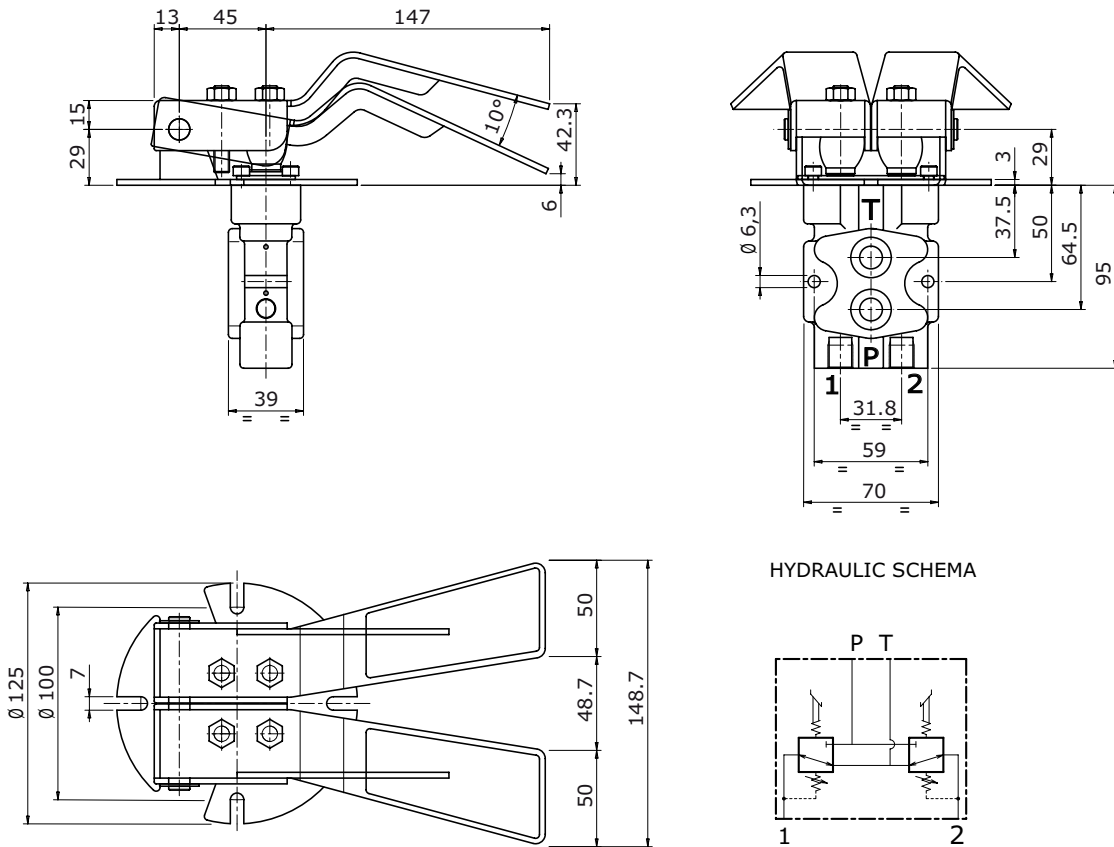



DOUBLE FOOT PEDAL LOWER PORTS **RCD**

ORDER EXAMPLE = RCD: 01S - A01 - MA - RA G02

- RCD product type _____
- 1 CONTROL CLASSIFICATION:** _____
- 01S** control type _____
- 2 METERING CURVE:** _____
- A01** curve type _____
- 3 RETURN SPRING:** _____
- MA** return spring type _____
- 4 BODY ARRANGEMENT:** _____
- RA** body specification _____
- G02** body thread _____

Ordering row 2 and 3, must be repeated for each port
 complete sample: **RCD: 01S A01 MA A01 MA RA G02**

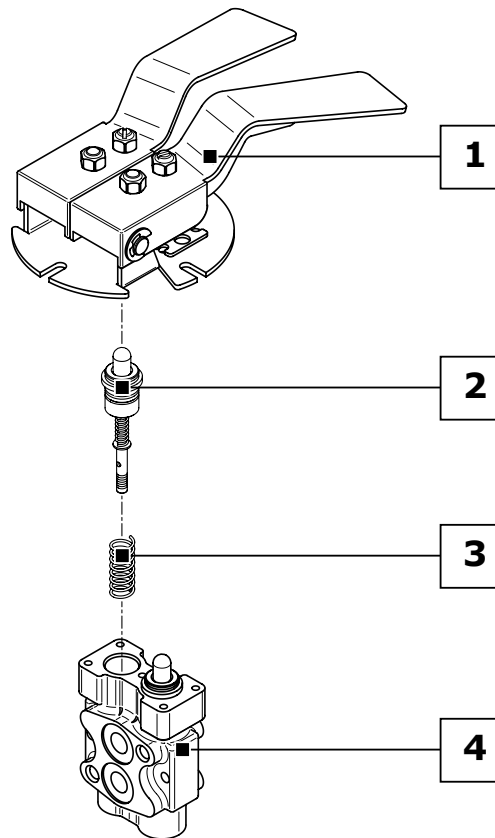

1	CONTROL CLASSIFICATION: (page 44)
01S	Foot pedal with return spring in neutral
2	METERING CURVE: (page 70)
A01	Linear metering curve with step
B01	Linear metering curve without step
C01	Broken line metering curve with step
D01	Broken line metering curve without step

3	RETURN SPRING: (page 79)
MA	Preload 25 N - End stroke load 48 N
MB	Preload 14 N - End stroke load 27 N
MC	Preload 73 N - End stroke load 135 N
MD	Preload 89 N - End stroke load 169 N
4	BODY ARRANGEMENT: (page 45)
RA G02	Standard Body (G 1/4 ports)
RA U02	Standard Body (9/16"-18 UNF ports)



RCD DOUBLE FOOT PEDAL LOWER PORTS

CONTROL KIT CLASSIFICATION

The pedal RCD has only one configuration; for different applications refer to our Commercial Dept.

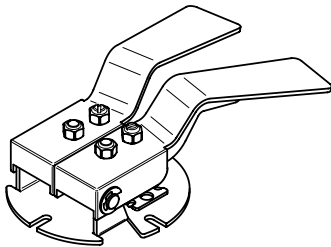
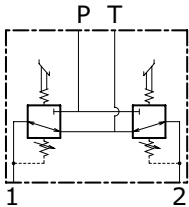
Code	Configuration	Schema	Description
01S			Foot pedal with return spring in neutral



DOUBLE FOOT PEDAL LOWER PORTS **RCD**

BODY ARRANGEMENT

The foot pedal RCD has only one setting body, the only variable is represented by a different thread.

Code	Configuration	Schema	Description
RA G02			Standard body with ports G 1/4
RA U02			Standard body with ports 9/16" - 18 UNF



RCS FOOT PEDAL LOWER PORTS

RCS is a single pedal version remote control. It's a new family completing the broad range of remote control. This pedal work according to the principle of direct-acting pressure reducing valves. In rest position, the foot pedal is held in neutral by return spring; inlet port P is closed and ports are connected to tank port T. Its ergonomic design provides optimum comfort for the operator.



TECHNICAL SPECIFICATIONS

Max pressure: **100 bar**

Oil capacity: **12 l/min**

Weight: **4,1 Kg**

APPLICATIONS

Mini-excavators

RCS DIMENSIONS STANDARD

HYDRAULIC SCHEMA

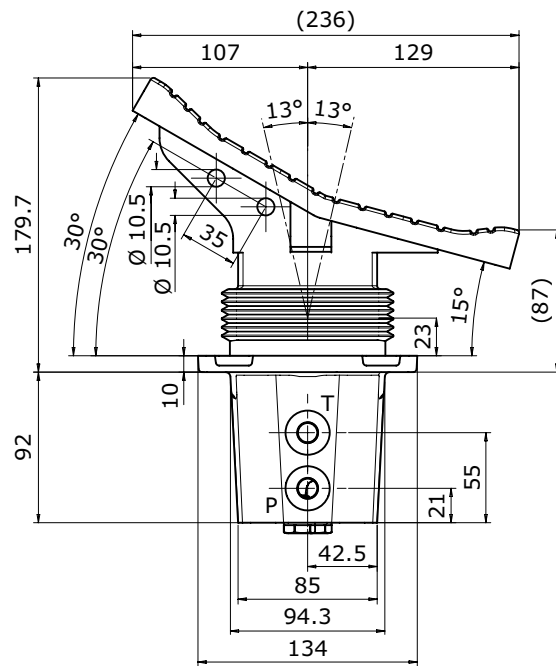
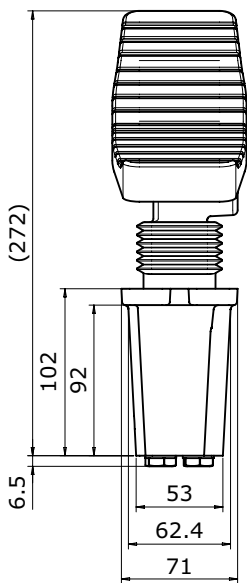
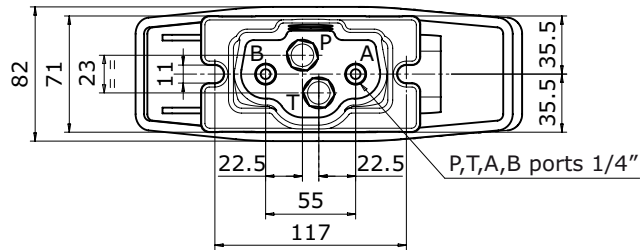
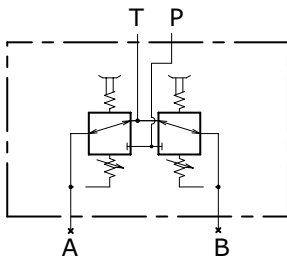



FOOT PEDAL LOWER PORTS **RCS**

RCS DIMENSIONS WITH NARROW BODY

The special design with narrow body is suitable for use on small machines.

HYDRAULIC SCHEMA

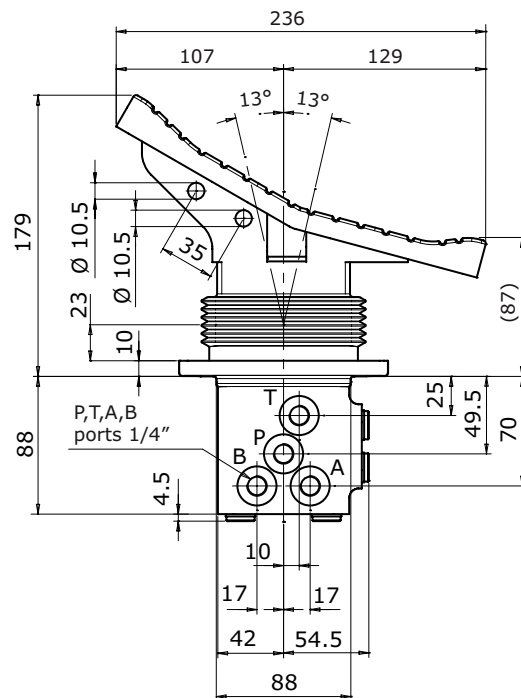
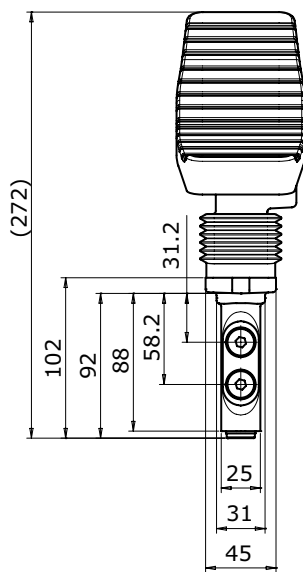
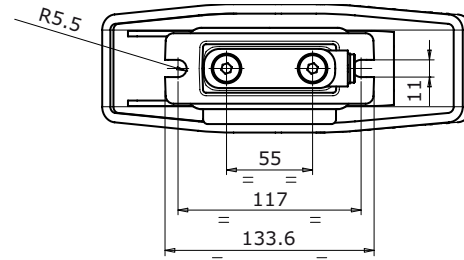
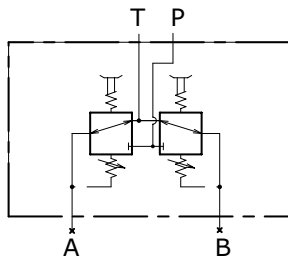



RCS FOOT PEDAL LOWER PORTS

ORDER EXAMPLE = RCS: 02P - 01S - A01T - MD - RA01 G02

- RCS product type _____
- 1 PEDAL CLASSIFICATION:** _____
- 02P** pedal type
- 2 CONTROL CLASSIFICATION:** _____
- 01S** control type
- 3 METERING CURVE:** _____
- A01T** curve type
- 4 RETURN SPRING:** _____
- MA** return spring type
- 5 BODY ARRANGEMENT:** _____
- RA01** body specification
- G02** body thread

Ordering row 3 and 4, must be repeated for each port
complete sample: **RCS: 02P 01S A01T MD A01T MD RA01 G02**

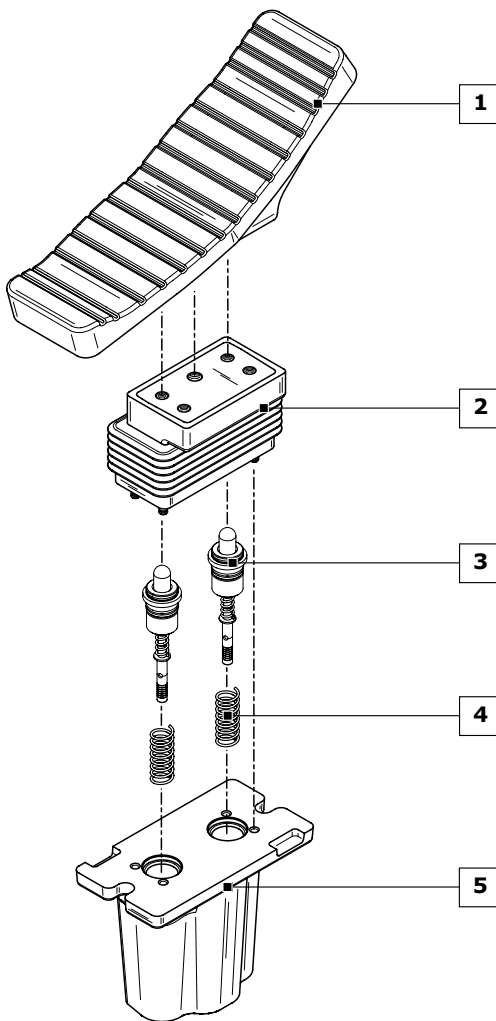

1	PEDAL CLASSIFICATION: (page 49)
00P	Without pedal (prearrangement)
01P	Standard flat pedal
02P	Short pedal tilted 30°
03P	Long pedal tilted 30°
2	CONTROL KIT CLASSIFICATION: (page 49)
01S	Control kit with bellows
2	METERING CURVE: (page 74)
A01T	Linear metering curve with step (tipo A)
B01T	Linear metering curve without step (tipo B)
4	RETURN SPRING: (page 79)
MD	Preload 94 N - End stroke load 149 N
5	BODY ARRANGEMENT: (page 50)
RA01 G02	P - T lower (G 1/4 ports)
RA02 G02	P - T side (G 1/4 ports)
RA11 G02	P - T front A - B lower (G 1/4 ports)
RA12 G02	A - B - P - T side (G 1/4 ports)
RA01 U02	P - T lower (9/16-18 UNF ports)
RA02 U02	P - T side (9/16-18 UNF ports)
RA11 U02	P - T front A - B lower (9/16-18 UNF ports)
RA12 U02	A - B - P - T side (9/16-18 UNF ports)

PEDAL CLASSIFICATION

All controls installed on the foot pedal RCS are interchangeable. Pedals represented correspond to standard configurations; for different applications contact our Commercial Dept.

Code	Dimensions	Configuration	Description
00P			Without pedal (prearrangement)
01P			Standard flat pedal with rubber protection
02P			Short pedal tilted 30° with rubber protection
03P			Long pedal tilted 30° with rubber protection

CONTROL KIT CLASSIFICATION

Only one configuration is available; for different applications contact our Commercial Dept.

Code	Dimensions	Configuration	Description
01S			Control kit with bellows

Metering curves are available equipped with a swing-preventing dampening device; for more informations contact our Commercial Dept.



RCS FOOT PEDAL LOWER PORTS

STANDARD BODY ARRANGEMENT

The listed configurations are all the possible combinations that can be obtained with the RCS standard body; two different pitch threads are available. For different applications contact our Commercial Dept.

Code	Configuration	Description
RA01 G02		Standard body (ports P-T lower) with ports G 1/4
RA01 U02		Standard body (ports P-T lower) with ports 9/16" - 18 UNF
RA02 G02		Body (ports P-T side) with ports G 1/4
RA02 U02		Body (ports P-T side) with ports 9/16" - 18 UNF
RA03 G02		Body (ports A-B-P-T side) with ports G 1/4
RA03 U02		Body (ports A-B-P-T side) with ports 9/16" - 18 UNF
RA04 G02		Body (ports A-B side) (ports P-T lower) with ports G 1/4
RA04 U02		Body (ports A-B side) (ports P-T lower) with ports 9/16" - 18 UNF

FOOT PEDAL LOWER PORTS **RCS**

NARROW BODY ARRANGEMENT

The listed configurations are all the possible combinations that can be obtained with the RCS narrow body; two different pitch threads are available. For different applications contact our Commercial Dept.

Code	Configuration	Description
RA11 G02		Standard body (ports P-T front) (ports A-B lower) with ports G 1/4
RA11 U02		Standard body (ports P-T front) (ports A-B lower) with ports 9/16" - 18 UNF
RA12 G02		Body (ports A-B-P-T side) with ports G 1/4
RA12 U02		Body (ports A-B-P-T side) with ports 9/16" - 18 UNF
RA13 G02		Body (ports P-T side) (ports A-B lower) with ports G 1/4
RA13 U02		Body (ports P-T side) (ports A-B lower) with ports 9/16" - 18 UNF
RA14 G02		Body (ports P-T front) (ports A-B side) with ports G 1/4
RA14 U02		Body (ports P-T front) (ports A-B side) with ports 9/16" - 18 UNF



RCT DOUBLE FOOT PEDAL LOWER PORTS

RCT is a double pedal version remote control. It's a new family completing the broad range of remote control. Different pedal designs are available: flat, bent, extended bent for an optimal ergonomic solution. This pedal work according to the principle of direct-acting pressure reducing valves. In rest position, the foot pedal is held in neutral by return spring; inlet port P is closed and ports are connected to tank port T.



TECHNICAL SPECIFICATIONS

Max pressure: **100 bar**

Oil capacity: **12 l/min**

Weight: **5,1 Kg**

APPLICATIONS

Mini-excavators

DIMENSIONS

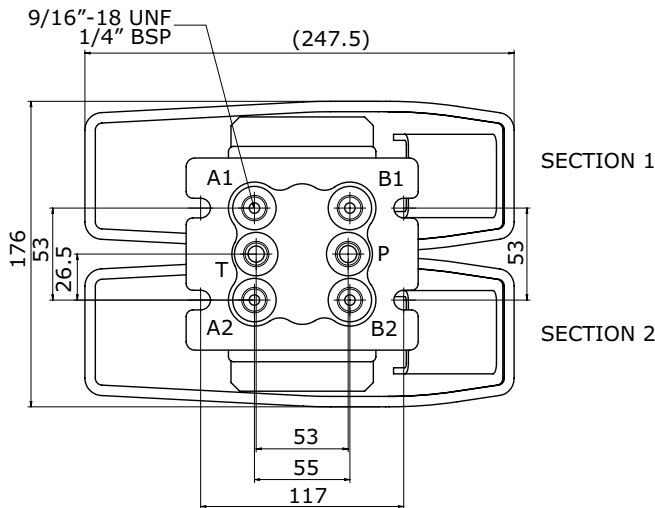

HYDRAULIC SCHEMA

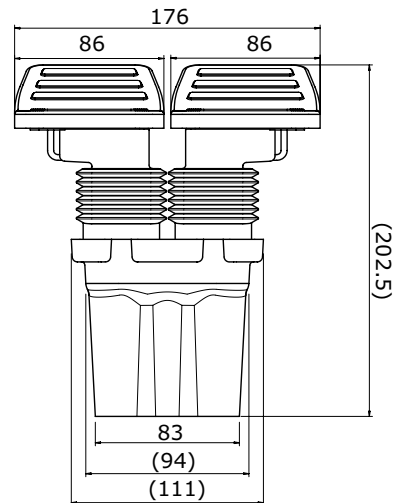
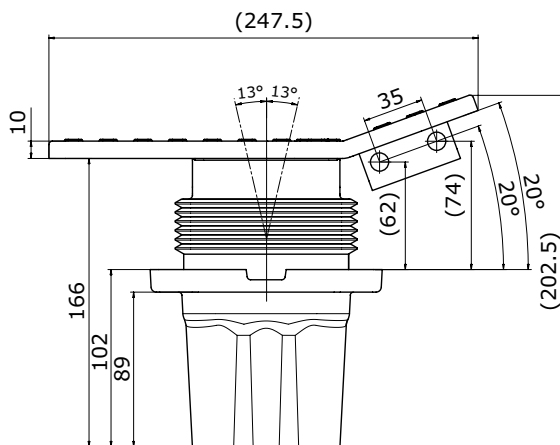
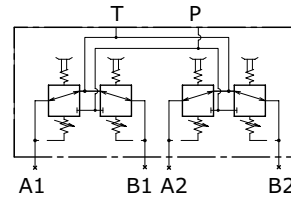



DOUBLE FOOT PEDAL LOWER PORTS **RCT**

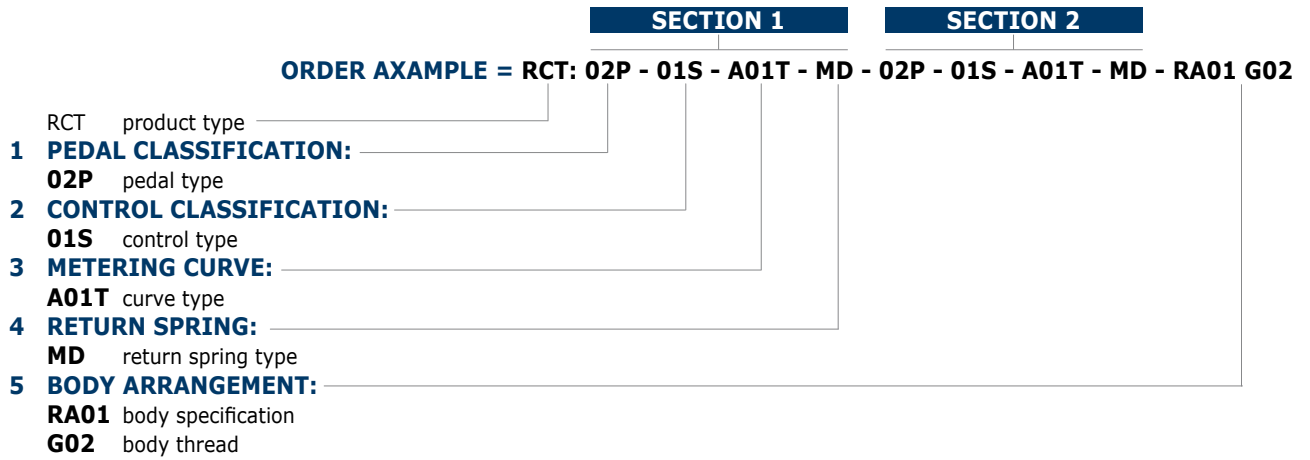

Ordering row 1, 2, 3, and 4 must be repeated for each section. Each section contains 2 curves and 2 springs.

COMPLETE EXAMPLE

RCT: 02P 01S A01T MD A01T MD - 02P 01S A01T MD A01T MD - RA01 G02

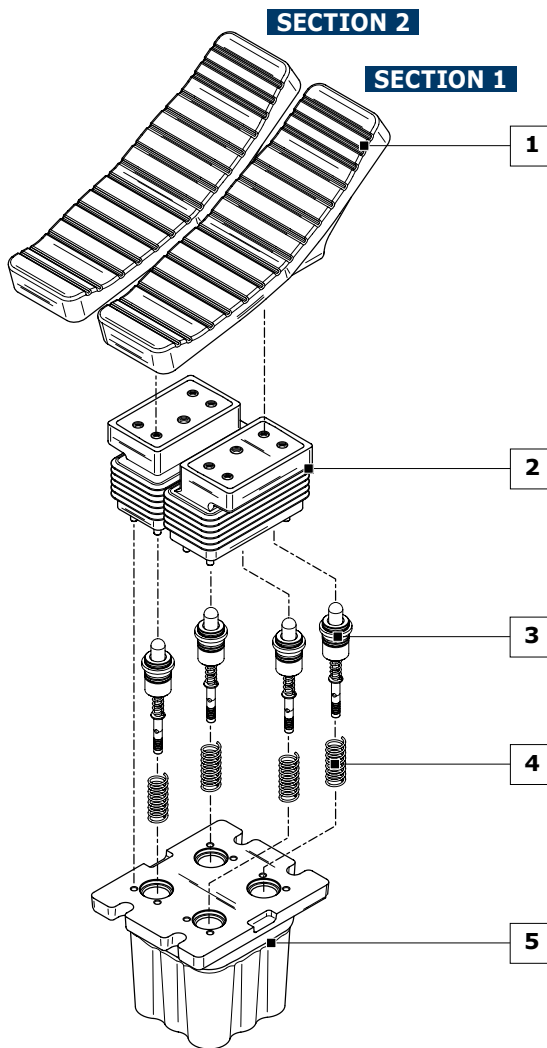

1	PEDAL CLASSIFICATION: (page 54)
00P	Without pedal (prearrangement)
01P	Standard flat pedal
02P	Short pedal tilted 30°
03P	Long pedal tilted 30°
2	CONTROL KIT CLASSIFICATION: (page 55)
01S	Control kit with bellows
2	METERING CURVE: (page 74)
A01T	Linear metering curve with step (tipo A)
B01T	Linear metering curve without step (tipo B)
4	RETURN SPRING: (page 79)
MD	Preload 94 N - End stroke load 149 N
5	BODY ARRANGEMENT: (page 56)
RA01 G02	P - T lower (G 1/4 ports)
RA02 G02	P - T side (G 1/4 ports)
RA11 G02	P - T front A - B lower (G 1/4 ports)
RA12 G02	A - B - P - T side (G 1/4 ports)
RA01 U02	P - T lower (9/16-18 UNF ports)
RA02 U02	P - T side (9/16-18 UNF ports)
RA11 U02	P - T front A - B lower (9/16-18 UNF ports)
RA12 U02	A - B - P - T side (9/16-18 UNF ports)



RCT DOUBLE FOOT PEDAL LOWER PORTS

PEDAL CLASSIFICATION

All controls installed on the foot pedal RCT are interchangeable. Pedals represented correspond to standard configurations; for different applications contact our Commercial Dept.

Code	Dimensions	Configuration	Description
00P			Without pedal (prearrangement)
01P			Standard flat pedal with rubber protection
02P			Short pedal tilted 30° with rubber protection
03P			Long pedal tilted 30° with rubber protection



CONTROL KIT CLASSIFICATION

Only one configuration is available; for different applications contact our Commercial Dept.

Code	Dimensions	Configuration	Description
01S			Control kit with bellows

Metering curves are available equipped with a swing-preventing dampening device; for more informations contact our Commercial Dept.



RCT DOUBLE FOOT PEDAL LOWER PORTS

STANDARD BODY ARRANGEMENT

The listed configurations are all the possible combinations that can be obtained with the RCT standard body; two different pitch threads are available; for different applications contact our Commercial Dept.

Code	Configuration	Description
RA01 G02		Standard body (ports P - T lower) with ports G 1/4
RA01 U02		Standard body (ports P - T lower) with ports 9/16" - 18 UNF
RA02 G02		Body (ports P-T side) with ports G 1/4
RA02 U02		Body (ports P-T side) with ports 9/16" - 18 UNF
RA03 G02		Body (ports A-B-P-T side) with ports G 1/4
RA03 U02		Body (ports A-B-P-T side) with ports 9/16" - 18 UNF



DOUBLE FOOT PEDAL LOWER PORTS **RCT**

BODY WITH SHUTTLE VALVE ARRANGEMENT

Bodies are available equipped with integrated shuttle valves to generate additional signals. The RA11 configuration includes a fifth port activated when any one of the four service ports is actuated (for safety, alert or brake release functions).

code	configuration	description
RA11 G02		Standard body with shuttle valves with ports G 1/4
RA11 U02		Standard body with shuttle valves with ports 9/16" - 18 UNF



RCV HYDRAULIC REMOTE CONTROL ONE SERVICE PORT

RCV is a general purpose single user remote control. It can be delivered with simple spring centering control, 360° regulating handle holding the control position or with pedal control. In rest position, the hydraulic remote control is held in neutral by return spring; inlet port P is closed and ports are connected to tank port T. By selecting control, plunger compresses return spring and reaction spring; consequently it shifts spool and opens connection holes between inlet port P and service ports. This causes a pressure increase on service ports that is proportional to the control stroke and the reaction spring.



TECHNICAL SPECIFICATIONS

Max pressure: **100 bar**

Oil capacity: **12 l/min**

Weight: **1 Kg**

APPLICATIONS

Forklifts, Tractors

DIMENSIONS

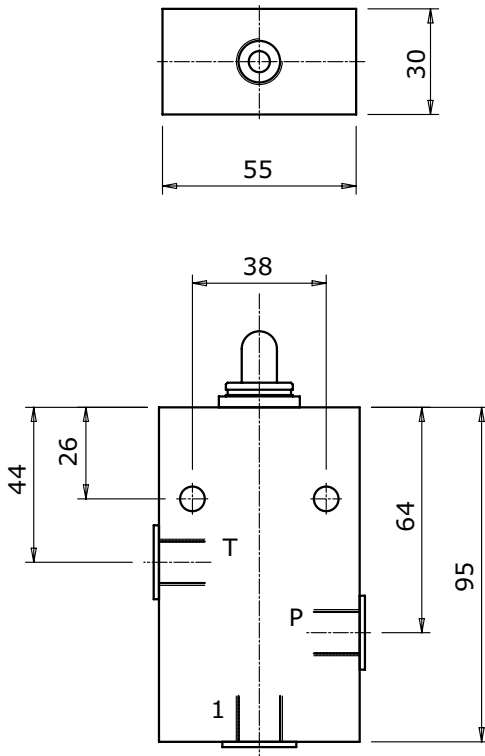

HYDRAULIC SCHEMA

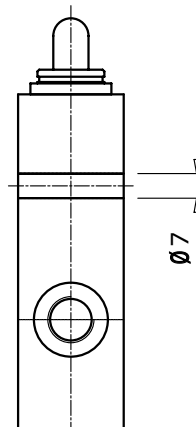
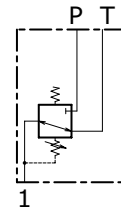



HYDRAULIC REMOTE CONTROL ONE SERVICE PORT **RCV**

ORDER EXAMPLE = RCV: 01V - A01 - MA - RA G02

RCV product type _____

1 CONTROL CLASSIFICATION: _____

01V control type

2 METERING CURVE: _____

A01 curve type

3 RETURN SPRING: _____

MA return spring type

4 BODY ARRANGEMENT: _____

RA body specification

G02 body thread

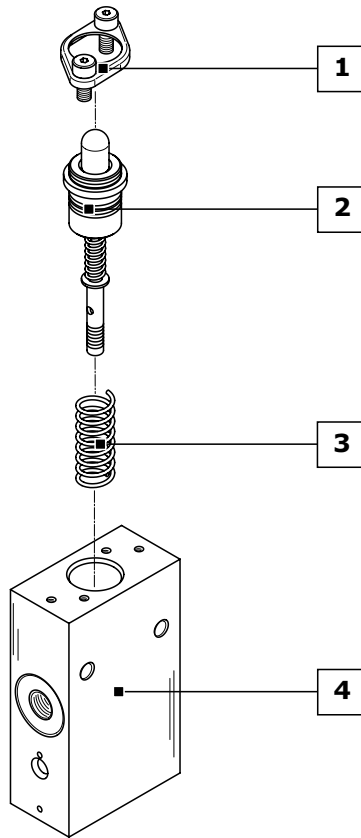

1	CONTROL CLASSIFICATION: (page 60)
00H	Without control with return spring in neutral position
01V	Wheel operated hydraulic remote control rotated 360° with stopping in each position
01S	Foot pedal with return spring in neutral position
2	METERING CURVE: (page 70)
A01	Linear metering curve with step
B01	Linear metering curve without step
C01	Broken line metering curve with step
D01	Broken line metering curve without step
3	RETURN SPRING: (page 79)
MA	Preload 25 N - End stroke load 48 N
MB	Preload 14 N - End stroke load 27 N
MC	Preload 73 N - End stroke load 135 N
MD	Preload 89 N - End stroke load 169 N
4	BODY ARRANGEMENT: (page 61)
RA G02	Standard Body (G 1/4 ports)
RA U02	Standard Body (9/16"-18 UNF ports)



RCV HYDRAULIC REMOTE CONTROL ONE SERVICE PORT

CONTROL KIT CLASSIFICATION

All controls installed on the foot pedal RCV are interchangeable: the controls shown correspond to standard configurations; for different applications contact our Commercial Dept.

Code	Dimensions	Schema	Description
00H			Without control with return spring in neutral position
01V			Wheel operated hydraulic remote control rotated 360° with stopping in each position
01S			Foot pedal with return spring in neutral position (standard)



HYDRAULIC REMOTE CONTROL ONE SERVICE PORT **RCV**

BODY ARRANGEMENT

The hydraulic remote control RCV has only one setting body, the only variable is represented by a different thread.

Code	Configuration	Schema	Description
RA G02			Standard body with ports G 1/4
RA U02			Standard body with ports 9/16" - 18 UNF



SU-SE HYDRAULIC REMOTE CONTROL ONE SERVICE PORT

The purpose of supply unit SU and SE is to fit hydraulic remote controls in an hydraulic system working at high pressure with reduced flow at low pressure.

The supply unit range is thus divided: **SU2, SU3, SE2, SE3**

SE3 can fit up to 3 dump valves (12 - 24 Vdc)



TECHNICAL SPECIFICATIONS

Max pressure: **350 bar**

Pressure on port line (U): **10-70 bar**

Maximum back pressure on tank line (T): **3 bar**

Minimum pressure (P1): **10 bar**

Oil capacity: **12 l/min**

APPLICATIONS

Pilot remote of: directional control valves, variable displacement pumps and motors, auxiliary valves, frictions and hydraulic brakes

SU2 DIMENSIONS

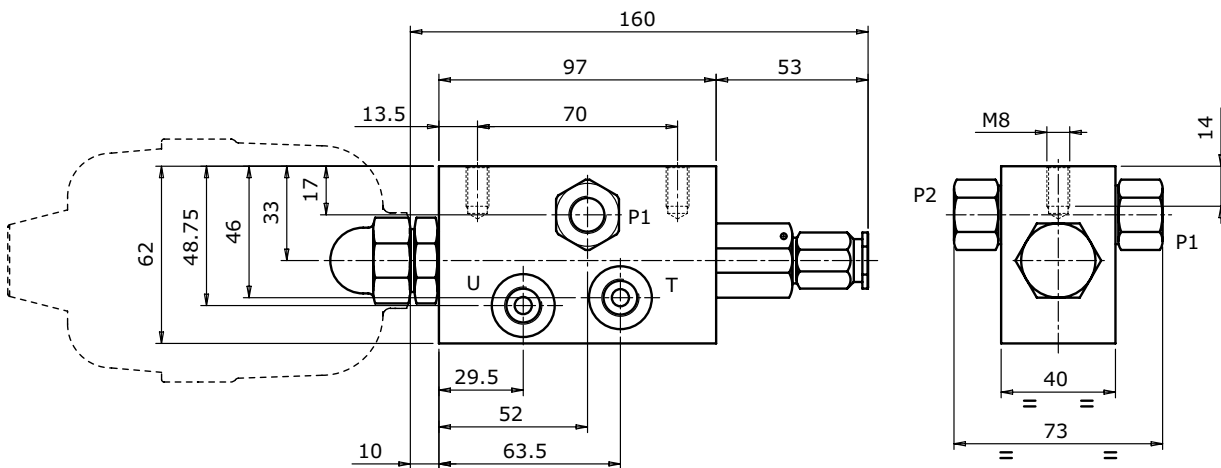

SU3 DIMENSIONS

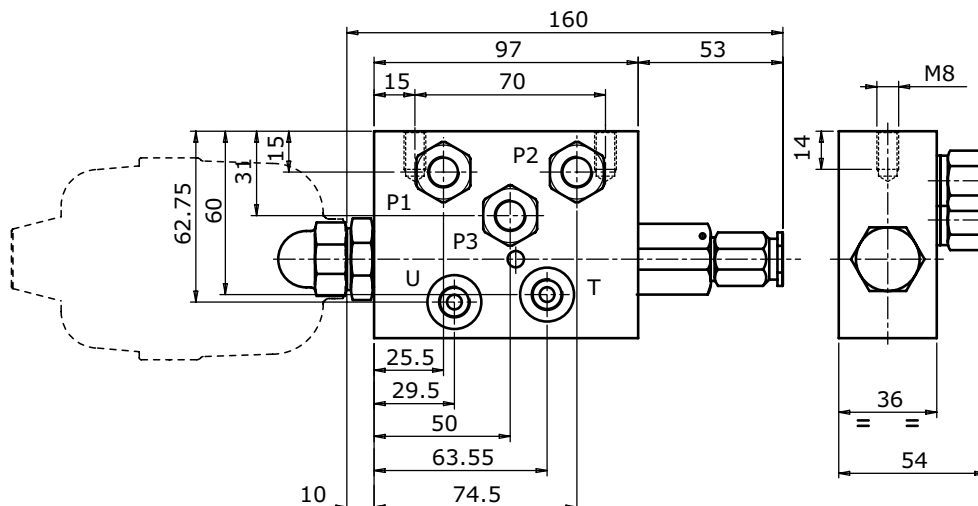



HYDRAULIC REMOTE CONTROL ONE SERVICE PORT

SU-SE

SE2 DIMENSIONS

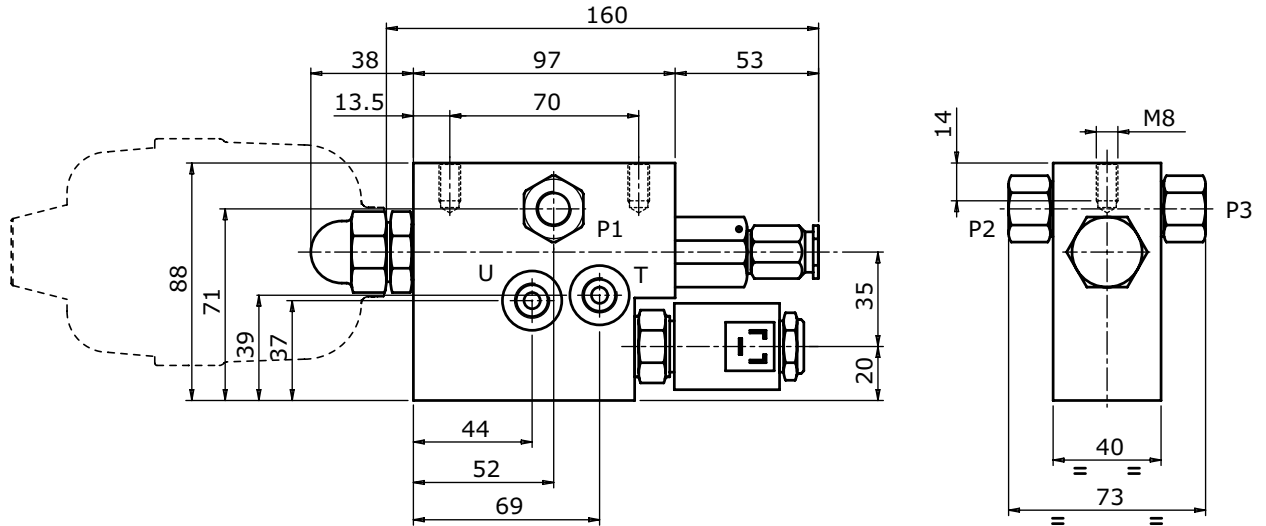

SE3 DIMENSIONS

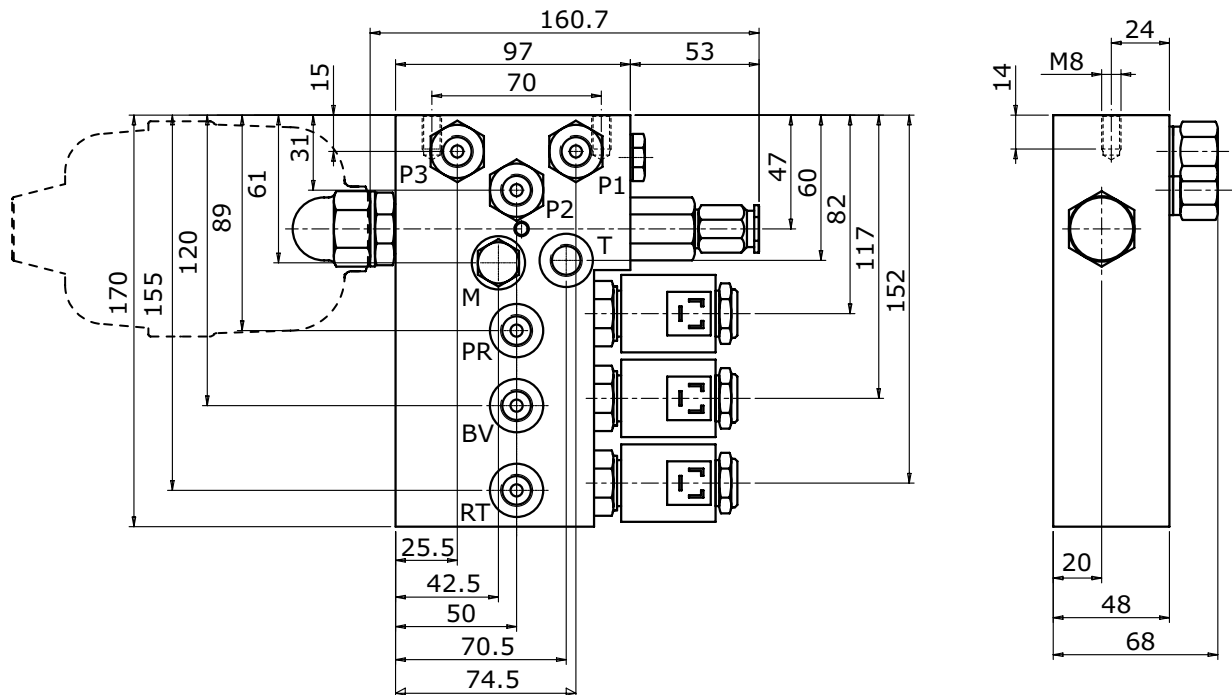



SU-SE HYDRAULIC REMOTE CONTROL ONE SERVICE PORT

ORDER EXAMPLE = SU2: V04 - 30 - RA G02

- SU product type _____
- 2 number of lines _____
- 1 ACCUMULATOR CLASSIFICATION:** _____
- V04** accumulator model _____
- 2 REDUCING VALVE:** _____
- 30** pressure setting (0-70 bar on service port U) _____
- 3 BODY ARRANGEMENT:** _____
- RA** body specification _____
- G02** body thread _____

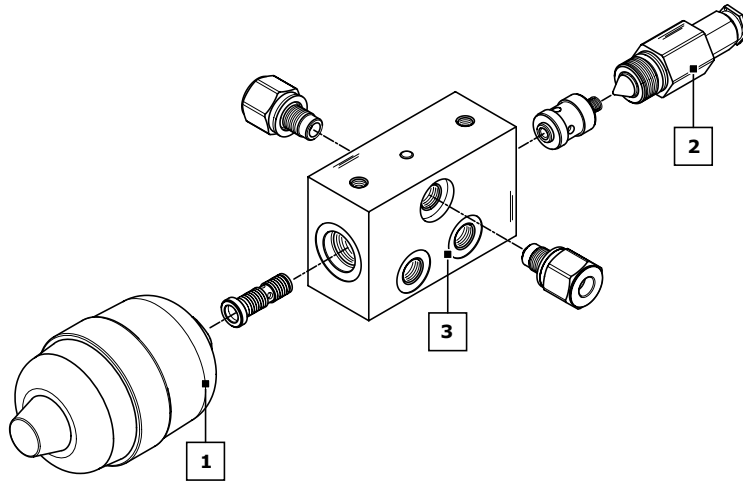

PRODUCT TYPE: (page 65)	
SU2	Two (P) lines supply unit at high pressure
SU3	Three (P) lines supply unit at high pressure
SE2	Supply unit with 2 inlets at high pressure and 1 outlet with reduced pressure (port U) with dump valve
SE3/1	Supply unit with 3 inlets at high pressure and 1 outlet with reduced pressure (port U) with dump valve
SE3/2	Supply unit with 3 inlets at high pressure and 2 outlets with reduced pressure (port BV-PR) with dump valve on each outlet
SE3/3	Supply unit with 3 inlets at high pressure and 3 outlets with reduced pressure (port BV-PR-RT) with dump valve on each outlet
1 ACCUMULATOR CLASSIFICATION CURVE: (page 66)	
V01	Without accumulator
V03	Prearranged for accumulator (1/2" BSP)
V04	Hydropneumatic accumulator with rubber membrane (Volume of nitrogen: lt. 0,35 - Precharge: 10 bar)
2 REDUCING VALVE:	
30	In the ordering code is necessary to indicate the pressure setting of reducing valve. setting range pressure: 0-70 bar
3 BODY ARRANGEMENT: (page 69)	
RA G02	Standard body (only for SU2) (G 1/4 ports)
RB G02	Standard body (only for SU3) (G 1/4 ports)
RV G02	Body with dump valve 12 Vdc (only for SE2 - SE3) (G 1/4 ports)
RW G02	Body with dump valve 24 Vdc (only for SE2 - SE3) (G 1/4 ports)
RA U02	Standard body (only for SU2) (9/16"-18 UNF ports)
RB U02	Standard body (only for SU3) (9/16"-18 UNF ports)
RV U02	Body with dump valve 12 Vdc (only for SE2 - SE3) (9/16"-18 UNF ports)
RW U02	Body with dump valve 24 Vdc (only for SE2 - SE3) (9/16"-18 UNF ports)



HYDRAULIC REMOTE CONTROL ONE SERVICE PORT **SU-SE**

SUPPLY UNIT CLASSIFICATION

Code	Schema	Configuration	Description
SU2			Two (P) lines supply unit at high pressure
SU3			Three (P) lines supply unit at high pressure
SE2			Supply unit with 2 inlets at high pressure and 1 outlet with reduced pressure (port U) with dump valve
SE3/1			Supply unit with 3 inlets at high pressure and 1 outlet with reduced pressure (port U) with dump valve
SE3/2			Supply unit with 3 inlets at high pressure and 2 outlets with reduced pressure (port BV-PR) with dump valve on each outlet
SE3/3			Supply unit with 3 inlets at high pressure and 3 outlets with reduced pressure (port BV-PR-RT) with dump valve on each outlet



SU-SE HYDRAULIC REMOTE CONTROL ONE SERVICE PORT

ACCUMULATOR CLASSIFICATION

Code	Schema	Dimensions	Description
V01			Without accumulator
V02			Prearranged for accumulator (M18x1,5)
V03			Prearranged for accumulator (1/2" BSP)
V04			Hydropneumatic accumulator with rubber membrane Volume of nitrogen: lt. 0,35 Precharge: 10 bar
V05			Hydropneumatic accumulator with rubber membrane Volume of nitrogen: lt. 0,75 Precharge: 10 bar
V06			Hydropneumatic accumulator with rubber membrane Volume of nitrogen: lt. 1,50 Precharge: 10 bar



HYDRAULIC REMOTE CONTROL ONE SERVICE PORT

SU-SE

ACCUMULATORS TECHNICAL SPECIFICATIONS			
Max. working pressure	Working temperature	Max. allowed pressure ratio	Accumulator precharge pressure
210 bar	-20°C +80°C	< 6/1	10 bar

SETTING DIAGRAM, REDUCING VALVE, RELIEF VALVE

Because of the small dimensions and working on the same adjusting screw, this valve has the possibility of setting both the pressure reducing valve and the main relief valve. Main relief valve pressure setting is higher than about 10 bar if compared to the pressure reducing valve - see the pressure setting diagram. Supply unit may be installed in any mounting position but the accumulator should be as far as possible from heat sources..

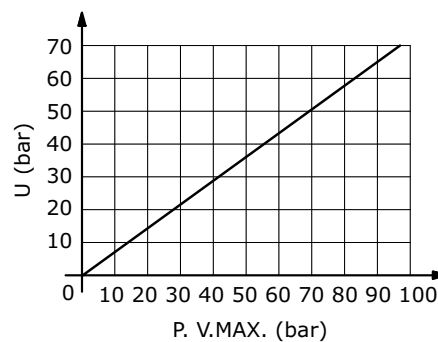

**SU-SE** HYDRAULIC REMOTE CONTROL ONE SERVICE PORT**DUMP VALVE TECHNICAL SPECIFICATIONS**

Description	Value
Operating voltage	12 Vdc +/-20% - 24 Vdc +/-20%
Resistance at 20°C	7 W - 28 W
Power at 20°C	20,5 W
Utilization factor	ED100%
Class wrapping (IEC 85)	H
Connector	DIN 43650/ISO4400
Connector protection (EN 60529)	IP65

On request equipped counterpart connector DIN 43650/ISO4400. Ordering code: 413000313.



HYDRAULIC REMOTE CONTROL ONE SERVICE PORT **SU-SE**

BODY ARRANGEMENT

The body configuration of a supply unit changes according to the product used; BSP and UNF service ports are featured in every set-up. For different applications contact our Commercial Dept.

Code	Configuration	Description	SU2	SU3	SE2	SE3/1	SE3/2	SE3/3
RA G02		Standard body ports G 1/4	•					
RA U02		Standard body ports 9/16" - 18 UNF	•					
RB G02		Standard body ports G 1/4		•				
RB U02		Standard body ports 9/16" - 18 UNF		•				
RV G02		Body with dump valve (12 Vdc) ports G 1/4			•	•	•	•
RV U02		Body with dump valve (12 Vdc) ports 9/16" - 18 UNF				•	•	•
RW G02		Body with dump valve (24 Vdc) ports G 1/4			•	•	•	•
RW U02		Body with dump valve (24 Vdc) ports 9/16" - 18 UNF				•	•	•



METERING CURVE CLASSIFICATION

All the Hydrocontrol servo control configurations imply the choice of a "metering curve" kit; the number of metering curves changes according to the number of product service ports. The metering curve classification depends on the working pressure (measured in bars) and stroke length (measured in mm).

The sketch here below shows a typical metering curve and the list of available curves.

For information on the complete list of curves, contact the manufacturer's Commercial department.

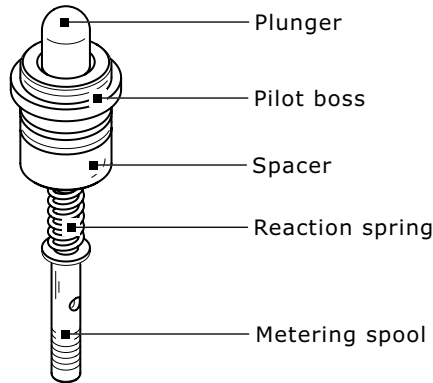

Type	Diagram	Description		
A	<p style="text-align: center;">Pressure (bar)</p> <p style="text-align: center;">Stroke (mm)</p>	<p>Linear metering curve with step</p>		
CODE	PRESSURE		STROKE	
	A (bar)	B (bar)	C (mm)	D (mm)
A01	5,8	19,5	1,5	7,5
A02	5	25	1,5	7,5
A03	2	13	1,5	7,5
A04	6	40	1,5	7,5
A05	0	64	1,5	7,5
A06	4	17	1,5	7,5
A07	5	15	1,5	7,5
A08	2	18	1,5	7,5
A09	5	20	1,5	6
A10	2	8	1,5	7,5
A11	4	10	1,5	7,5
A12	11,5	32	1,5	7,5
A13	10	20	1,5	7,5
A14	7	17	1,5	7,5
A15	7,5	29	1,5	7,5



CODE	PRESSURE		STROKE	
	A (bar)	B (bar)	C (mm)	D (mm)
A16	6	22	1,5	7,5
A17	0	20	1	7,5
A18	4	16	1,5	7
A19	6	20,6	1,5	7
A20	8	28	1,5	7,5
A21	5	20,5	1,5	7,5
A22	5,8	18,3	1,5	7
A23	6,8	23,5	1	7,5
A24	5,8	19,2	1	9,5
A25	4,4	17,9	1	6,5
A26	2,8	20,8	1,5	10
A27	5,7	19,1	1,5	7,5
A28	3	16,2	1,5	7,5
A29	8	27,6	1,5	9,5
A30	5,8	15,5	1,5	7,5
A31	5,6	25,2	1,5	7,5
A32	7	15,5	1,2	7,5
A33	10,7	27,5	1	7,5
A34	0	28	1,5	7,5
A35	5,8	24	1,5	9,5
A36	7,4	21	1,5	7,5
A38	7,5	17,7	1,5	7,5
A39	6,6	16,4	1,5	7,5
A40	6,5	11,6	1,5	7,5
A41	5,9	17,4	1,5	7,5
A42	6,6	16,3	1,5	9,5
A43	3	22,2	1,5	7,5
A44	14,5	26,9	1	7,5
A45	8,7	39,2	1,5	7,5
A46	4	22	1,5	7,5
A47	14,7	28,4	1,5	7,5
A48	5	74	1	7,5
A49	0	34	1,5	7,5
A51	7,3	21,7	1,5	7
A52	10	79	1	7,5
A54	4	20	1,5	7,5
A55	3	20	4,5	7,5
A56	5	20	1,5	4,5
A61	5	19	1,5	7
A62	8	22	1,5	7,5
A64	6,8	26	1,5	7,5
A65	6,8	24,4	1,5	7
A67	2,5	14	1	7,5
A68	7,5	20,9	1,5	9,5
A99	6	19	1	3,5



Type	Diagram	Description		
B		Linear metering curve without step		
CODE	PRESSURE		STROKE	
	A (bar)	B (bar)	C (mm)	D (mm)
B01	5	22	1,5	8
B02	5	19	1,5	8
B03	5	16	1,5	8
B04	2	16,5	1,5	8
B05	7,5	32,5	1	8
B06	5	20	1	8
B07	4	10,5	1,5	8
B08	3	14,5	1,5	8
B09	6	24,3	1	8
B10	2	19,3	1,5	8
B11	7,1	21,9	1	8
B12	8,3	23,2	1	8
B13	7,9	23,6	1	8
B14	6	23	1,5	8
B15	10,2	25,8	1	8
B16	6,9	12,4	1,5	8
B17	2,1	20,3	1	8
B18	5,8	27	1,5	8
B19	3,2	24,4	1,5	8
B20	2	8,5	1,5	8
B21	2	13,7	1,5	8
B22	5,8	16,4	1,2	7,7
B23	4	18	1,5	8
B24	10,2	25,1	1	8
B25	4,5	23,9	1,5	8
B27	7,5	18,9	1	8
B29	3	23,8	1,5	8
B30	6	42	1,5	8
B31	4	29	1	8
B35	6,5	20	1	8
B36	7,8	20,2	1	8
B98	6	14,5	1,2	8
B99	4,5	14,5	1,5	8



Type	Diagram	Description				
C		Broke line metering curve with step				
CODE	PRESSURE			STROKE		
	A (bar)	B (bar)	C (bar)	D (mm)	E (mm)	F (mm)
C01	2	6	15	1,5	5	7,5
C02	3	7	16	1,5	5	7,5
C03	7	18	27	0,5	4,8	6,5
C04	7	18	27	0,5	6,3	8
C05	5	11	18	1	5	7,5
C07	4,2	9	20	1,5	5	7,5
C08	6,5	11	18,5	1	5	7,5
C10	5,4	10,9	17,3	1	5	7,5
C11	4,2	9	20	1,5	5	7,5
C98	1	2,5	9	1	4,2	8,5
C99	1	2,5	9	1	4,2	9

Type	Diagram	Description				
D		Broke line metering curve without step				
CODE	PRESSURE			STROKE		
	A (bar)	B (bar)	C (bar)	D (mm)	E (mm)	F (mm)
D01	2	6	15	1,5	5	8
D02	4,2	9	22	1	5	8
D04	5	16,2	20	1,5	7,5	8
D07	4,2	9	22,2	1,5	5	8



METERING CURVE CLASSIFICATION FOR FOOT PEDAL RCS - RCT

The RCS and RCT tilting foot controls imply the use of limited-stroke dedicated curves guaranteeing improved control ergonomics. Metering curves are available equipped with a swing-preventing dampening device; for more informations contact our Commercial Dept.

Type	Diagram	Description		
A		Linear metering curve with step		
CODE	PRESSURE		STROKE	
	A (bar)	B (bar)	C (mm)	D (mm)
A01T	5,8	19,5	1	5
A02T	5	25	1	5
A06T	4	17	1	5
A07T	5	15	1	5
A16T	6	22	1	5
A20T	8	28	1	5
A52T	5	22	1	5
A53T	6	26	1	5



Type	Diagram	Description		
B	<p>Pressure (bar) B</p> <p style="text-align: center;">C D Stroke (mm)</p>	<p>Linear metering curve without step</p>		
CODE	PRESSURE		STROKE	
	A (bar)	B (bar)	C (mm)	D (mm)
B03T	5	16	1	5,5
B14T	6	23	1	5,5
B23T	4	18,6	1,5	5
B32T	5	27,5	1,5	5
B40T	6	18,7	1	4,2



METERING CURVE CLASSIFICATION FOR HYDRAULIC REMOTE CONTROL RCL - RCY

The RCL and RCY hydraulic remote controls imply the use of dedicated curves, specially designed to reduce actuation forces. The available choices are shown here below.

Type	Diagram	Description		
A	<p>Pressure (bar)</p> <p>B</p> <p>A</p> <p>C D Stroke (mm)</p>	Linear metering curve with step		
CODE	PRESSURE		STROKE	
	A (bar)	B (bar)	C (mm)	D (mm)
A01	5,8	19,5	1,5	7,5
A02	5	25	1,5	7,5
A06	4	17	1,5	7,5
A07	5	15	1,5	7,5
A14	7	17	1,5	7,5
A21	5	20,5	1,5	7,5
A23	6,8	23,5	1	7,5
A24	5,8	19,2	1,5	9,5
A35	5,8	24	1,5	9,5
A36	7,4	21	1,5	7,5
A37	7,3	19,3	1,5	7
A47	14,7	28,4	1,5	7,5
A50	5	26,8	1	7,5
A53	6	26	1,5	7,5
A54	4	20	1,5	7,5
A57	6,6	22,7	1,5	7,5
A59	5	26,8	1	6,5
A60	5	26,8	1	8,5
A65	6,5	23,7	1,5	7,5
A69	5,6	21,6	1,5	7,5
A70	6,5	23,7	1	7,5
A71	6,9	25,2	1,5	9,5
A72	9,2	27,5	1,5	9,5



Type	Diagram	Description		
B		Linear metering curve without step		
CODE	PRESSURE		STROKE	
	A (bar)	B (bar)	C (mm)	D (mm)
B06	5	20	1	8
B09	6	24,3	1	8
B28	8,2	26,8	1	8
B33	5,9	24,8	1,5	8
B37	5	15,8	1,5	8
B38	6,3	21,2	1,5	8
B39	2,7	15	1,5	8
B41	5	26,6	1,5	8
B42	5,8	25,1	1,5	10

Type	Diagram	Description				
D		Broke line metering curve without step				
CODE	PRESSURE			STROKE		
	A (bar)	B (bar)	C (bar)	D (mm)	E (mm)	F (mm)
D03	5,2	14,4	30,9	1,5	5	8



PREFEELING - MECHANICAL DETENT

The prefeeling function enables users to safely lock the lever adjustment without accidentally reaching the point of detent. When choosing from the metering curves shown, the reduced adjustment stroke should be taken into consideration, and a curve should be chosen allowing the required pressure value to be reached at the prefeeling stage.

The RCX and RCY hydraulic remote controls have a prefeeling setting at 5.7 mm along the stroke in combination with the mechanical detent (code 02).

The RCX, RCY prefeeling effect on the A01 curve is shown by way of example.

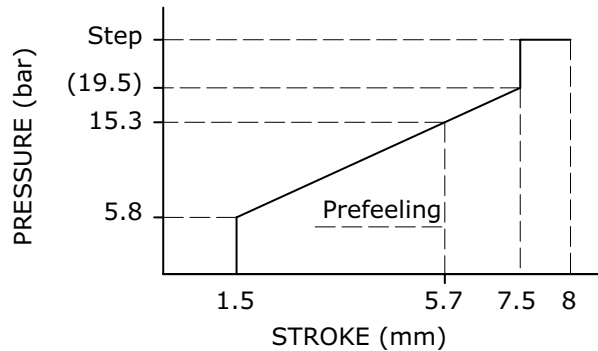

Similarly, the RCM and RCB hydraulic remote controls have a prefeeling setting at 6.9 mm along the stroke in combination with the mechanical detents (codes 02, 03 and 04).

The RCM, RCB prefeeling effect on the A01 curve is shown by way of example.

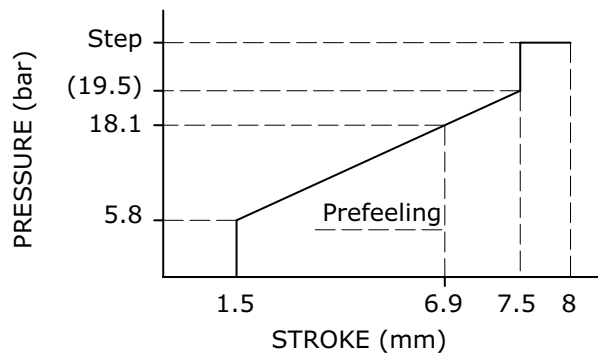

PREFEELING - ELECTROMAGNETIC DETENT

The RCL and RCL3 hydraulic remote controls are designed with prefeeling before the electromagnetic detent point is reached. In this case, the prefeeling is set at 7 mm along the stroke.

The RCL, RCL3 prefeeling effect on the A01 curve is shown by way of example.

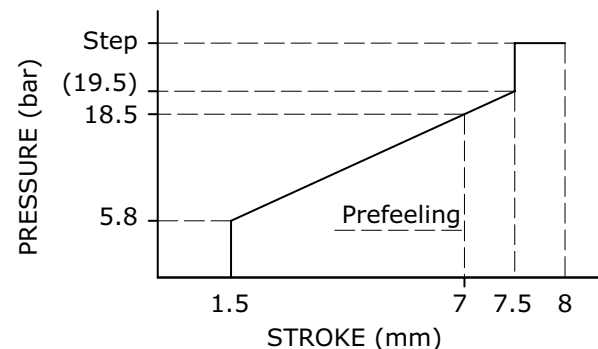



RETURN SPRING CLASSIFICATION

For all the servo control configurations designed by Hydrocontrol, in each service port and on the relevant metering curve, a return spring must be selected.

The exploded view here below shows the example configuration of a 4 service port remote control; as you can see, a return spring is pictured at each metering curve. 4 types of return spring are currently available (see table).

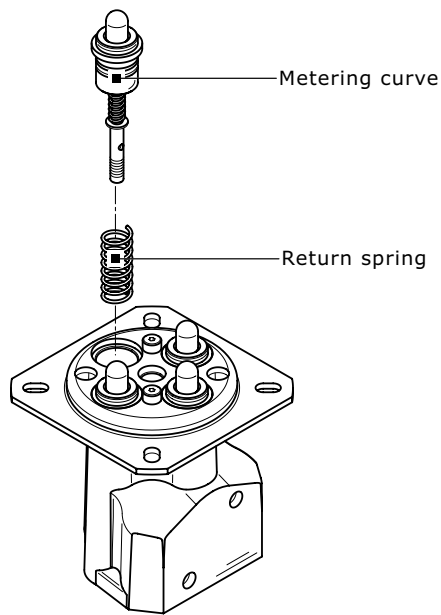

CODE	PRELOAD	END STROKE LOAD
MA	25 N	48 N
MB	14 N	27 N
MC	73 N	135 N
MD	89 N	169 N

RETURN SPRING CLASSIFICATION FOR RCS AND RCT







The range of RCS and RCT tilting foot controls only includes the MD type return spring. The relative values are shown here below.

CODE	PRELOAD	END STROKE LOAD
MD	94 N	149 N

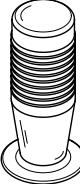
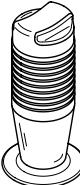

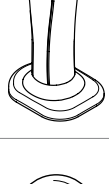
HANDLES CLASSIFICATION

All the hydraulic remote controls manufactured by Hydrocontrol can be set up to have different handles according to the system dimensions and applications. All the handles in the range are shown here below; for each handle, the corresponding operation is also pictured. The choice of a handle will also influence the choice of a lever kit.

HANDLE IDENTIFICATION - QUICK REFERENCE GUIDE								
Type	Description	RCX	RCY	RCL	RCL3	RCM	RCB	
A	 Handle without micro-switch	•	•			•		
B	 Handle with micro-switch to close	•	•			•		
C	 Handle with micro-switch to close with detent	•	•			•		
D	 Handle with dual micro-switch	•	•			•		
F	 Ergonomic handle	•	•	•	•			
M	 Handle with lens					•	•	
S	 Ergonomic handle slim	•	•	•				
K	 Spherical handle	•	•					



HANDLES "A - B - C - D"

The handle families identified with A, B, C and D have been designed to equip the vast range of earth-moving machines including mini-excavators, mini-loaders, brush cutters, backhoe loaders, tractors, etc.

These handles can be set up to have – or not – a microswitch.

The hydraulic remote controls most suitable for fitting these handles are HC-RCX, HC-RCY and HC-RCM.

Type	Description	Dimensions	Configuration
A	without micro-switch (standard)		
B	with micro-switch to close		
C	with micro-switch to close with detent		
D	with dual micro-switch		

HANDLES MICROSWITCH BREAKING B - C - D

MICROSWITCH SPECIFICATIONS	
Direct current load resistive	4.8 A 30 Vdc
Alternative current load resistive	1.5 A 30 Vdc
TECHNICAL SPECIFICATIONS	
Hande protection	IP 40



HANDLE "F"

This handle has been designed to be used on our remote controls type RCX. Its ergonomics, the accurate buttons position and dimensions make its use comfortable and restful. It can be supplied with 7 microswitches in different combinations together with a push button for safety.

Type	Description	Dimensions	Configuration
F	Ergonomic handle		

TECHNICAL SPECIFICATIONS

BUTTONS COLOURS	
Type A	red
Type B - C	yellow
Type D - E	green
Type F - G	grey
Type H (push button for safety)	black
MICROSWITCH SPECIFICATIONS	
Direct current load resistive	5 A 30 Vdc
Direct current load inductive	3 A 30 Vdc
TECHNICAL SPECIFICATIONS	
Handle protection	IP 65
Cable section	0,5 mm ²
Useful cable length	700 mm

ORDER EXAMPLE HANDLE "F"

05F - 01R - 2 - WF53

- 1 **FRONT BUTTONS ARRANGEMENT:** _____
- 05F** arrangement with 5 front buttons
- 2 **REAR BUTTONS ARRANGEMENT:** _____
- 01R** arrangement with 1 rear button
- 3 **HANDLE POSITION (RESPECT TO THE BODY):** _____
- 2** return spring type
- 4 **LEVER ROD CLASSIFICATION:** _____
- WF53** type and length rod lever straight
- WG51** type and length rod lever bent
- WH48** type and length rod lever bent



FRONT BUTTONS ARRANGEMENT		
Code	Drawing	Schema
00F		
01F		<pre> A E- 1 2 </pre>
02F		<pre> B C E- E- 3 4 5 6 </pre>
03F		<pre> A B C E- E- E- 1 2 3 4 5 6 </pre>
04F		<pre> B C D E E- E- E- E- 3 4 5 6 7 8 9 10 </pre>
05F		<pre> A B C D E E- E- E- E- E- 1 2 3 4 5 6 7 8 9 10 </pre>

REAR BUTTONS ARRANGEMENT		
Code	Drawing	Schema
00R		
01R		<pre> F E- 11 12 </pre>
02R		<pre> F G E- E- 11 12 13 14 </pre>
03R		<pre> H E- 15 16 </pre>
04R		<pre> F H E- E- 11 12 15 16 </pre>
05R		<pre> F G H E- E- E- 11 12 13 14 15 16 </pre>



HC-SADR2 SILENT ALERTER DRIVER - HANDLE "F" WITH VIBRATION

SADR2 with vibration (silent alarm) is an ergonomic handle which, via a 'dead man' control, can transmit different frequency vibrations to the operator's hand. The handle can be equipped with up to three microswitches in its front side, while the rear side is always equipped with the 'dead man' control button; the special mechanical control design of the "Dead Man" button is necessary for vibration transmission. In addition to transmitting the required vibration, this button also works as an active button.

APPLICATION FIELD

The vibrating handle can be used to control crane trucks when the crane operator is not in a position to visually supervise the hanging load movement; in this case, the different-frequency vibration conveys to the operator information regarding the load movement and speed when visual or acoustic alarms would not be equally effective.

TECHNICAL SPECIFICATIONS

ELECTRIC	
Operating voltage	19.2 - 28.8 Vdc
Max current consumption (in standby)	80 mA
INPUT	
Input pulse frequency	0 - 65 Hz
Input pulse high level	17 - 28.8 Vdc
OUTPUT	
Alerting frequency	0 - 65 Hz
Max solenoid current (RMS)	800 mA
Protections	Reverse battery, "load-dump"
EM Immunity	30 V/m
MECHANICAL - ENVIRONMENTAL	
Operating temperature	-40 / +85 °C
Connections	Not terminated 3 conductors shielded cable
APPLIED STANDARDS	
EMC - Agricultural and forestry machines	EN 14982
EMC - Earth moving machinery	ISO 13766

ORDER EXAMPLE - "F" HANDLE WITH VIBRATION

The front of the handle can be equipped with up to 3 microswitches.

The order code are: **00F - 01F - 02F - 03F**

The choice of vibration corresponds to the ordering code 06R

		02F - 06R - 2 - WF53
1 FRONT BUTTONS ARRANGEMENT:	_____	
02F	arrangement with 2 front buttons	
2 REAR BUTTONS ARRANGEMENT:	_____	
06R	arrangement with vibration	
3 HANDLE POSITION (RESPECT TO THE BODY):	_____	
2	handle position	
4 LEVER ROD CLASSIFICATION:	_____	
WF53	type and length rod lever straight	
WG51	type and length rod lever bent	
WH48	type and length rod lever bent	

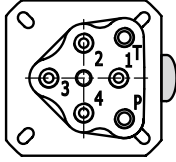
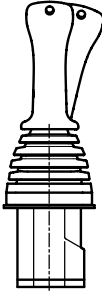
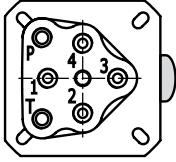
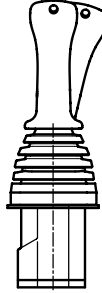
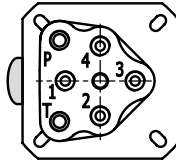
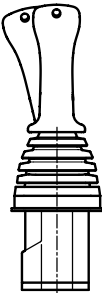
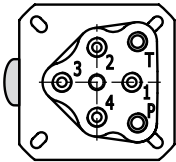
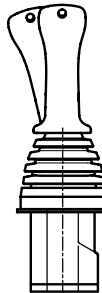
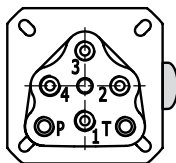
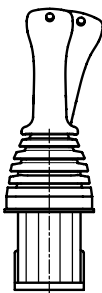
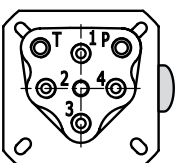
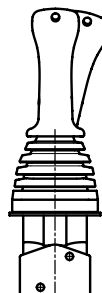
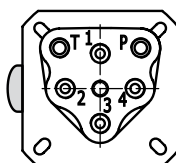
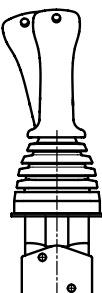
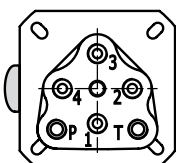
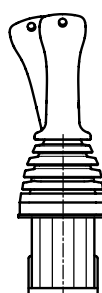

HANDLE POSITION "F" (RESPECT TO THE BODY)					
Code	Configuration	Code	Configuration		
1			5		
2			6		
3			7		
4			8		



HANDLE "S"

This handle has been designed to be used on our remote controls type RCX. Its small size and low cost make this handle a competitive alternative for all off-highway machines manufacturers. The handle is equipped with a top push button (3A / 125 Vac).

Type	Description	Dimensions	Configuration
S	Ergonomic handle slim		

ORDER EXAMPLE HANDLE "S"

2 - WS76

- 1 HANDLE POSITION (RESPECT TO THE BODY):** _____
- 2 LEVER ROD CLASSIFICATION:** _____
- WS76** type and length rod lever straight
 - WT69** type and length rod lever bent
 - WU65** type and length rod lever bent

HANDLE POSITION "S" (RESPECT TO THE BODY)					
Code	Configuration		Code	Configuration	
1			5		
2			6		
3			7		
4			8		



GENERAL CONDITIONS AND PATENTS

PRODUCT IDENTIFICATION

All Hydrocontrol products have an identifying plate placed in specific position.

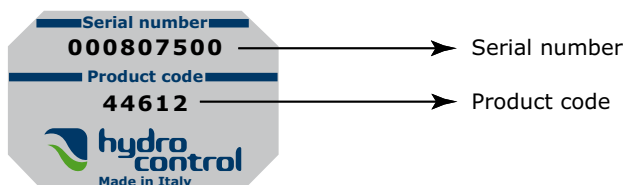

SERIAL NUMBER:

It univocally identifies the physical valve: this provides an easy way to find all sales and production details.

PRODUCT CODE:

It is a number univocally identifying the configuration and pressure settings of a valve.

INTRODUCTION

These general conditions apply to all general supplies from Hydrocontrol s.p.a., after receiving orders from the Customer. Should commercial terms such as EXW, DDP, etc be mentioned, of course the Incoterms of the International Chamber of Commerce must be referred to, according to the test existing when the general supply conditions are agreed on.

MANAGEMENT OF ORDERS

No Customer's order is binding to Hydrocontrol s.p.a. if Hydrocontrol s.p.a. has not confirmed the order in writing. Hydrocontrol s.p.a. commits to supplying the orders in compliance with the order confirmation that has been issued. Any disagreement with the content of the order confirmation must be communicated in writing to Hydrocontrol s.p.a. within and no later than 5 days from the delivery of the order confirmation. The Customer commits to paying for the goods supplied by Hydrocontrol s.p.a., according to the prices indicated on the order confirmation.

PAYMENT CONDITIONS

The Parties agree on the payment terms at the beginning of the supply. The terms will be indicated on the order confirmation. Should the Customer be late with the payments, Hydrocontrol S.p.a. will be entitled to require the payment of interests on arrears based on the exiting Prime Rate increased by 2%. Should there be any payment delay, Hydrocontrol s.p.a. will be entitled not to process the Customer's purchase order, even if it has already been confirmed.

DELIVERY AND SHIPMENT

The goods are always supplied Ex Works, even when Hydrocontrol s.p.a. agrees with the Customer that the shipment, or a part of it, will be arranged by Hydrocontrol s.p.a. It is agreed that the Customer will bear the risk of goods deterioration or damaging from the moment the goods are handed by Hydrocontrol s.p.a. to the first carrier.

PRODUCT CHARACTERISTICS

Hydrocontrol s.p.a. commits to supplying good quality products, compliant with the technical specifications declared on the technical tables and on the catalogue. Hydrocontrol s.p.a, even without notice, at its own discretion, reserves the right to modify the products as necessary, without these changes altering the main characteristics of the products.

CLAIMS

Any claims about defects on delivered products (just as an example: claims about the packaging, the number, the quantity or the external product characteristics) will have to be notified to Hydrocontrol s.p.a. in writing, within and no later than 7 days from reception of the goods, otherwise the claims will be considered as null and void. Occult defects (the defects of the goods that cannot be spotted with a careful control of the goods received by the Customer), will have to be notified in writing to Hydrocontrol s.p.a. within 7 days from the discovery of the defect, and anyhow no later than 12 months from the delivery of the goods, otherwise the claim will be considered as null and void. Even in case of claim or objection, the Customer will never be entitled to suspend or delay the payments to Hydrocontrol s.p.a. for the products subject to claim or objection nor for any other supply.



GENERAL CONDITIONS AND PATENTS

WARRANTY

Should the products supplied by Hydrocontrol not be compliant or have the required quality and should this defect be due to Hydrocontrol, Hydrocontrol s.p.a. commits, at its choice, to replace or repair the faulty products, as long as the defect or lack of compliance is notified to Hydrocontrol s.p.a. in writing, as specified at point 6, within and no later than 18 months from product delivery. On the products that have been fixed or replaced in accordance with what specified above, the above-mentioned warranty applies. The 12 month duration starts from the date of repair or replacement. In case of defects, lack of quality or in case of lack of compliance for the supplied products, with the exception of fraud or serious offence, Hydrocontrol s.p.a. only commits to repairing or replacing the faulty products, according to what specified above. This warranty replaces any other Supplier's warranty or liability established by the law. This warranty excludes any other liability contractual or extra-contractual by Hydrocontrol s.p.a. on the products supplied by Hydrocontrol (as a mere example: damage refund, loss of profit, product recall campaign, etc). Hydrocontrol s.p.a. has signed a product civil liability police, with a suitable maximum coverage.

OWNERSHIP RETENTION

The products supplied by Hydrocontrol s.p.a. will be owned by the latter until Hydrocontrol receives the complete payment for the supplied goods.

OBLIGATION CONFIDENTIALITY

Hydrocontrol s.p.a. commits to not disclosing the technical and commercial information it receives from the Customer, unless this information has already been publicly disclosed.

PATENTS

The Customer is not allowed to use the provided Products, or a part of them, their descriptions or drawings protected or not protected by Patent or registered trademark in order to design or make similar products, unless Hydrocontrol s.p.a. previously issues its written authorization. Should Hydrocontrol s.p.a. give its written authorization, all patents, trademarks, registered designs, copyrights and intellectual property rights related or connected to the Products provided by Hydrocontrol s.p.a. will stay Hydrocontrol's property. The Customer commits to respecting the highest confidentiality.

APPLICABLE LAW AND COURT OF JURISDICTION

Hydrocontrol s.p.a.'s supplies are regulated by these General Supply Conditions and, for anything not defined here, by the Italian law. Any controversy related, generated or connected to the supply of Products by Hydrocontrol s.p.a., where Hydrocontrol s.p.a. is involved, will be exclusively dealt with by the Court of Bologna.

Walvoil nel mondo - Walvoil worldwide
Sede principale, Filiali e Uffici di rappresentanza
Headquarters, Subsidiaries and Representative Offices

Walvoil S.p.A. - Headquarters

Via Adige, 13/D . 42124 Reggio Emilia . Italy
Phone +39 0522 932411 . info@walvoil.com - www.walvoil.com

Business Unit Hydrocontrol

Via San Giovanni, 481 . 40060 Osteria Grande
Castel S. Pietro Terme . Bologna . Italy
Phone +39 051 6959411

Galtech Site

Via Portella della Ginestra, 10 . 42025 Cavriago
Zona Industriale Corte Tegge . Reggio Emilia . Italy
Phone +39 0522 932411

AUSTRALASIA

Walvoil Fluid Power Australasia Pty Ltd

13 Vanessa Way . Delahey VIC 3037 . Melbourne . Australia
TEL. 0061 458 918 750 . australasia@walvoil.com

BRASILE . BRAZIL

Interpump Hydraulics Brasil Ltda - Walvoil Division

Gilberto de Zorzi, 525 . Forqueta Caxias do Sul (RS)
TEL. 0055 54 3223 2373 . infobrasil@walvoil.com

CANADA

Galtech Canada Inc.

3100, Jacob Jordan . Terrebonne . Qc J6X 4J6 . Canada
Phone +1 450 477 1076 Ext:225 . info@galtechcanada.com

CINA . CHINA

Walvoil Fluid Power (Shanghai) Company Limited

24, Lane 129, Dieqiao Road . Pu Dong . Kanqiao Industrial Zone Shanghai (201319)
TEL. 0086 21 60979800 . info@walvoil.com.cn

Guangzhou Bushi Hydraulic Technology Ltd

Shangwei Shaheshe, Yuehu Village . Xiancun, Xintang Town . Zengcheng City
511335 Guangzhou . Guangdong Province China
Phone +86 021 52380695 . fareast@hydrocontrol-inc.com

COREA . KOREA

Walvoil Fluid Power Korea Ltd. - SOUTH KOREA

80-15, Oseongsandan 1Ro, Oseong-Myun, Pyungtaek, Kyungki . Korea 451-872
TEL. +82 31 682 6030 . info@walvoil.co.kr

FRANCIA . FRANCE

Walvoil Fluid Power France

362 rue de Bretagne . 44540 Vritz
TEL. 0033 2 41 94 41 06 . france@walvoil.com

INDIA

HC Hydraulic Technology(P) LTD

A5(B) Ngef Ancillary Indl. Estate . Whitefield Road
Mahadevpura (Po) . Bangalore 560048 . India
Phone +91 080 40454707 . info@hydrocontrol-india.com

Walvoil Fluid Power (India) PVT. LTD.

No 23, Doddanakundi Industrial Area Mahadevapura Post Behind Graphite India
Bangalore 560 048
TEL. 0091 80 41842900 . info@walvoil.co.in

U.S.A.

Hydrocontrol Inc.

1109, Technology Drive . Red Wing . MN 55066 . U.S.A.
Phone +1 651 212 6400 . usa@hydrocontrol-inc.com

Walvoil Fluid Power Corporation

4111 North Garnett Tulsa, OK 74116, USA
TEL. 001 918 858 7100 . info@walvoilfluidpower.com

